

All Flash 32-Bit Microcontrollers

V850ES/Hx2

V850ES/Jx2

V850ES/Kx2



Empower your creativity

V850
Embedded Controller

Flash ^{2nd Stage}

Shifting to "All Flash"

Following 8-bit general-purpose microcontrollers, NEC Electronics will now manufacture all 32-bit general-purpose microcontrollers as flash products.

Toward a New Stage of "Shifting to All Flash," supporting a Manufacturing Revolution

The "Shifting to All Flash" concept consists in switching to flash memory products for the entire lineup of microcontrollers offered by NEC Electronics. After switching to flash products for our 8-bit microcontrollers in a first stage, we are now switching to a lineup of flash products for our 32-bit microcontrollers in a second stage. These new microcontrollers use the V850ES high-performance CPU core, which achieves 29MIPS at 20 MHz. The lineup features pin counts of 64 to 144 pins and ROM capacities of 64 KB to 640 KB. While boasting high performance and sophisticated functions, it is offered at low prices equivalent to those of the 16-bit microcontroller market. Naturally, the entire infrastructure, from development to delivery, that is the result of our experience in 8-bit All Flash microcontrollers, is available. By offering a lineup of products and environment resources that allow full use of the merits of flash memory products, namely stock reduction, fast delivery, and flexible adaptation to fluctuations in demand, NEC Electronics supports the realization of a manufacturing revolution for customers.

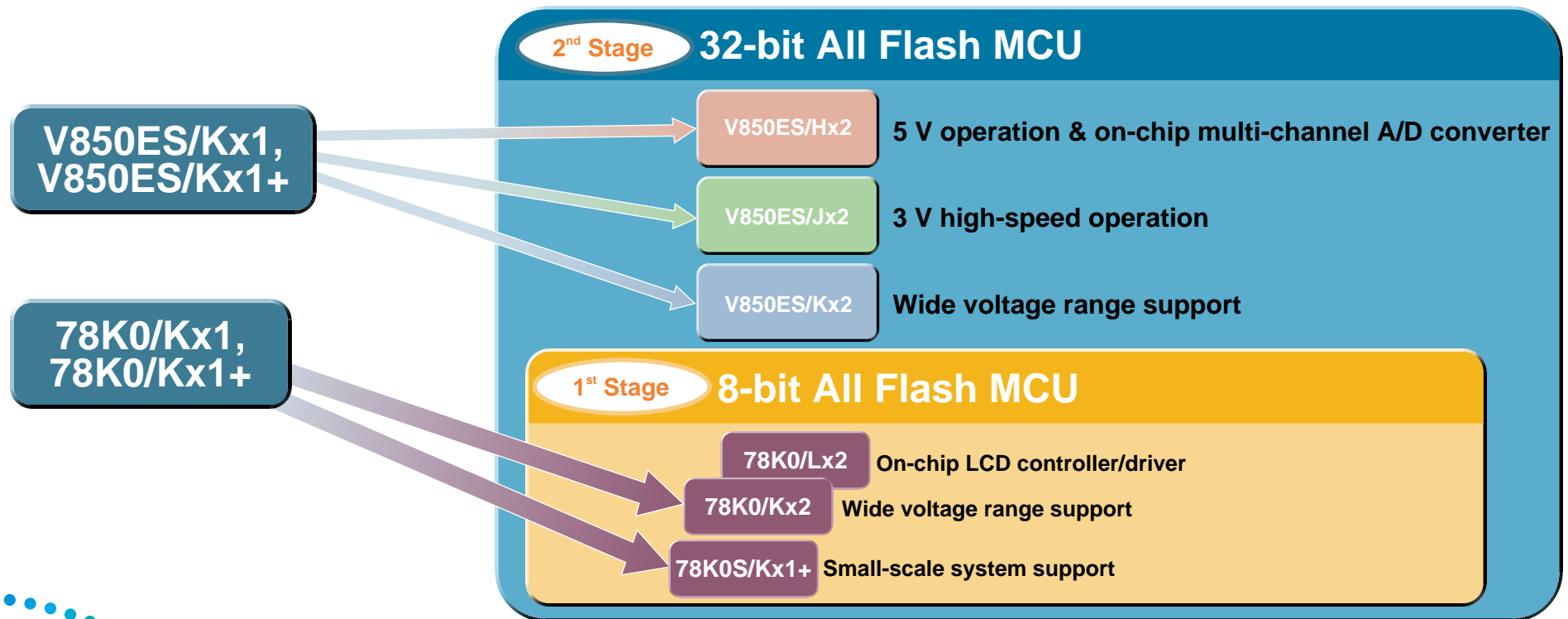

All Flash product lineup

- Expanded from 8-bit to 32-bit -
The V850 Series, positioned as a high-end series of the 78K Series, has been added to the All Flash product lineup.

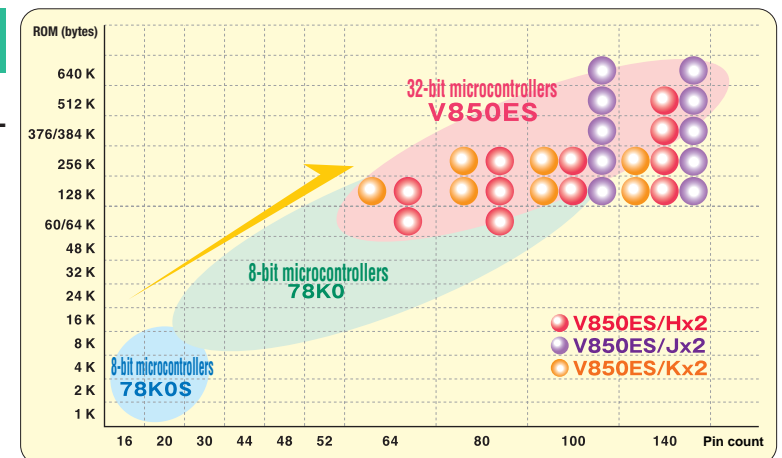

Application examples

All Flash microcontrollers are suitable for systems that use 16-bit microcontrollers and 32-bit microcontrollers; moreover, they add value to the systems.

 <p>Industrial equipment Industrial motors, control equipment, vending machines, power meters</p>	 <p>Camera Digital still cameras, digital video cameras, SLR cameras</p>  <p>Portable devices PDA, IC recorders</p>	 <p>Home appliances Air conditioners, refrigerators, washing machines, microwave ovens</p>  <p>Computer peripherals Laser-beam printers, inkjet printers, scanners, fax machines</p>	 <p>Video and recording equipment DVD players, D-VHS, industrial cameras</p>  <p>Audio Portable audio, component stereo systems</p>	 <p>Other Electronic instruments, electric bidets, toys, learning devices, remote controllers, etc.</p>
---	--	--	---	---



Providing flash microcontrollers is one way that NEC Electronics contributes to reforming the consumer supply chain.

Flash microcontrollers offer overwhelming advantages.

Compared to mask ROM microcontrollers, flash microcontrollers definitely contribute to speeding up system development. Microcontrollers can be ordered before program completion, programs can be written even after the microcontroller has been mounted on the board, and thus microcontroller order placement and program development can be done concurrently, allowing TAT to be shortened as a result.

In addition, when flash microcontrollers are used for products with an ample lineup or that are localized for specific regions, ordering costs necessitated by mask ROM microcontrollers can be reduced and purchase and stock management costs can be slashed.

For software designers



Software can be changed just before mass production starts; development TAT can also be shortened.

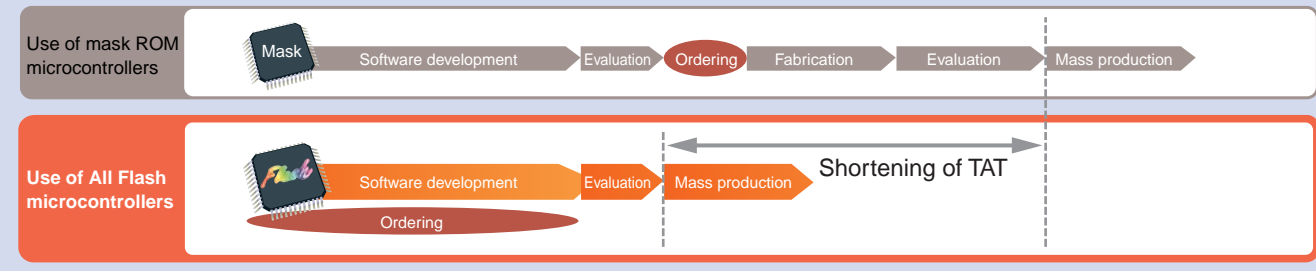

Since mask ROM microcontrollers cannot be ordered until their specifications are finalized, last-minute software changes can be problematic. On the other hand, specifications for flash microcontrollers can be changed just prior to the start of mass production. Thus orders for flash microcontrollers can be placed while the software is still being developed, allowing the development TAT to be shortened.

For hardware designers



Mass-produced flash microcontrollers require evaluation only once, reducing development man-hours.

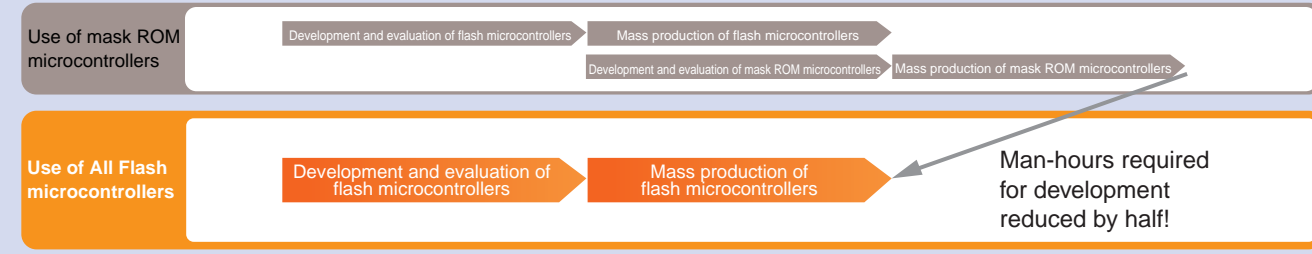

In the case of mass-produced mask ROM microcontrollers, evaluations of both flash microcontrollers and mask ROM microcontrollers are required. Since evaluated flash microcontrollers can directly be mass-produced, the man-hours required for development are reduced by half, resulting in greatly shortened development TAT.

For purchasing divisions



Flash microcontrollers protect you from fluctuations in demand, can reduce dead stock.

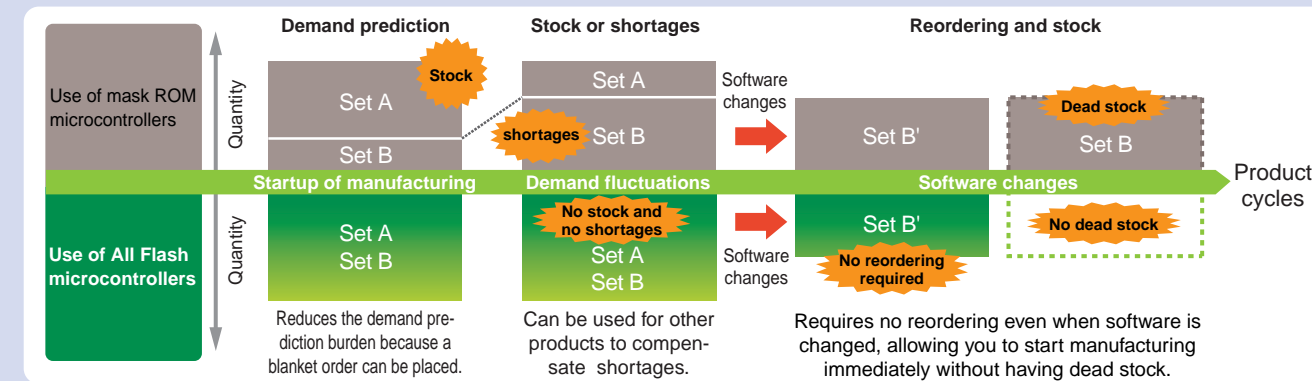

Mass-produced mask ROM microcontrollers may become dead stock as the result of changes in software or fluctuation in demand. On the other hand, flash microcontrollers can be mass-produced immediately after software changes and used for other products, resulting in fewer lost opportunities, less dead stock, and lower ordering cost.

For manufacturing divisions



Parts sharing makes production planning easier and boosts production efficiency.

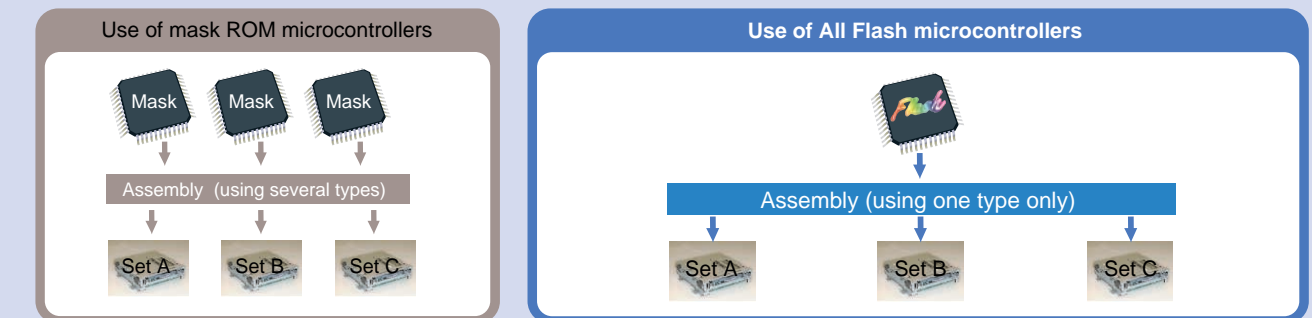

In the case of mass-produced mask ROM microcontrollers, the use of different software for different products necessitates the use of a different microcontroller for each type of product. In contrast, mass-produced flash microcontrollers facilitate the sharing of parts since they can be used for various products by simply rewriting the software.

Worried about taking your first steps?

The V850 All Flash will help put you at ease.



Reliability assured about adopting new products

For applications with large-scale programming and complicated systems, the burdens of development are great, so anxiety is even greater when it comes to adopting new products. The V850 All Flash will help to eliminate the anxiety

of adopting new products, by reviewing not only products themselves, but all other related aspects, including development, production, and distribution.

Large selection

3 series and 33 packages available

We have a total lineup of 33 flash microcontrollers with the same CPU core, with 3 series from which to choose: the V850ES/Hx2, V850ES/Jx2, and V850ES/Kx2.

With memories of from 64 to 640 KB, and packages of 64 to 144 pins, the ideal product for your needs can be selected from our extensive product lineup, according to the voltage range or processing performance required by your application.

ROM size (bytes)	RAM size (bytes)			
	64-pin	80-pin	100-pin	144-pin
640 K	V850ES/Hx2 (48 K)		V850ES/Hx2 (48 K)	
512 K	V850ES/Jx2 (40 K)		V850ES/Jx2 (20 K)	V850ES/Jx2 (40 K)
384 K / 376 K	V850ES/Kx2 (32 K)		V850ES/Kx2 (20 K)	V850ES/Kx2 (32 K)
256 K	12 K	12 K	12 K	12 K
128 K	6 K	4 K	12 K	6 K
64 K	6 K	12 K		

High performance

Offers performance of 29MIPS @ 20 MHz

A high-performance V850ES core of 29MIPS @ 20 MHz is used. The high performance goes far beyond enhancement of system functions, reducing the time required for software tuning.

You can also reduce the number of components by integrating into a single microcontroller for time-consuming processes which use two microcontrollers. Moreover, you can lower power consumption by dropping the frequency.

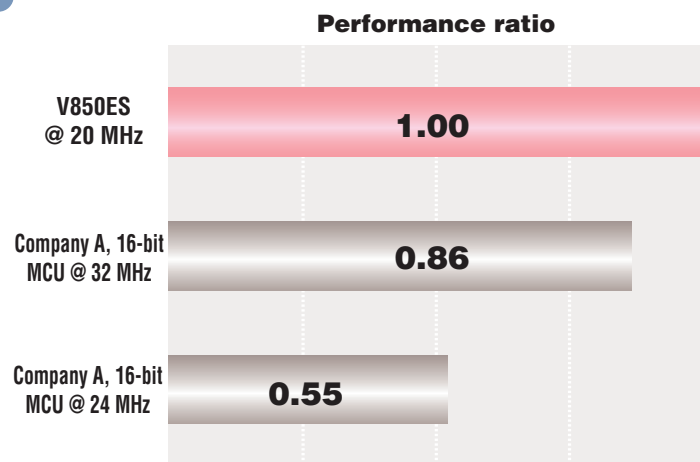

High reliability

Software protection based on experience, technology and security functions!

All our products incorporate the experience we have gained in the process of supplying more than 240,000,000 microcontroller units in cumulative shipment totals for more than 1,000 types of applications, and the technology we developed for flash microcontrollers for the automotive field. Our products also feature functions that disable reading and malicious software rewriting and erasing, thus offering maximum protection of your valuable software.

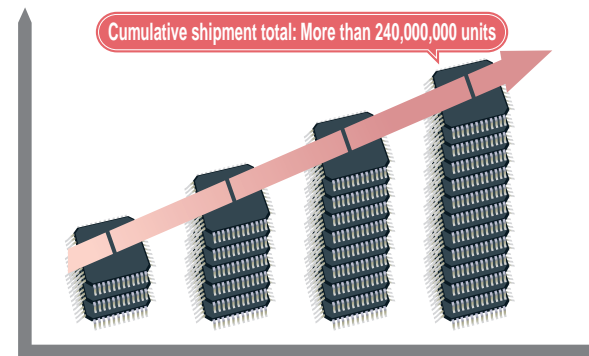

Ripe environment for development

Environment that reduces development burdens!

We provide inexpensive, easy-to-use, and convenient development environments, one example being an automatic driver software generation tool for peripheral functions. Driver software for peripheral functions, which is specific to the microcontroller, can be generated automatically just by clicking the buttons, which enables burdens for developing large-scale and complicated applications to be reduced.

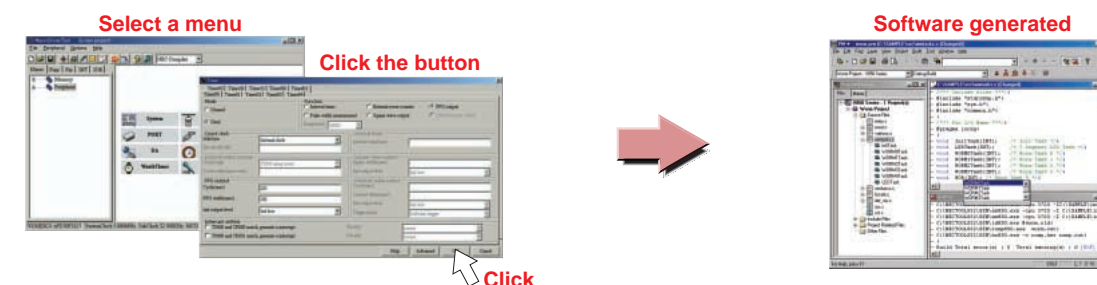

Support for mass production

Flash microcontroller mass production environment to meet your needs!







We provide flash microcontroller mass production environments serving a broad range of needs for flash microcontroller programming. For programming in your plants, we provide menus for introducing programming processes and various flash memory programmers for your purpose. Moreover, if you want programmed products, programming services in programming houses and supplying products programmed by NEC Electronics are also available.

Programming services and support for programming process

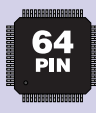
Programming by the customer	Programming by partner manufacturers
<p>Support for introducing in-line programming</p> <p>Naito Densai Machida Mfg. Co., Ltd. Yokogawa Digital Computer Corporation</p> <p>PG-FP4 (NEC Electronics) FL-PR4 (Naito Densai Machida Mfg. Co., Ltd.)</p> <p>NET IMPRESS (Yokogawa Digital Computer Corporation) Y1000-8 (Wave Technology Co., Ltd.)</p> <p>StickWriter (Application Corporation) ITF-2000 (Interface Co., Ltd.)</p> <p>Flash Gang Forward (Forward Electric Co., Ltd.)</p>	<p>Matsubara.KK GLOBAL PROGRAMMING SERVICES</p> <p>Synchro-work Corporation</p> <p>ROINTEC LIBERTY ertec</p> <p>Gleichmann JFS SOURCE</p> <p>Telford</p> <p>Flash programming houses Others</p> <p>Programmed microcontrollers</p> <p>NEC Electronics</p>

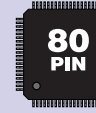
Large selection

We offer flash microcontrollers in various packages and ROM and RAM sizes, allowing you to select the best flash microcontroller for your product or application.

Pin count ROM Size	64-pin (E)	80-pin (F)	100-pin (G)	144-pin (J)
640 K	V850ES/Hx2 5 V operation & on-chip multi-channel A/D converter Ideal for 5 V power supply applications. 100-pin version features a 16 input-channel A/D converter. Ideal for applications with a large number of analog inputs.		μPD70F3719 (48 K)	μPD70F3724 (48 K)
512 K	V850ES/Jx2 3 V high-speed operation Ideal for high-speed control applications that use a 3 V power supply. Suitable for digital home appliances, which feature increasingly complex, highly functional, and high speed systems.		μPD70F3718 (40 K)	μPD70F3712 (20 K) μPD70F3723 (40 K)
376 K/ 384 K	V850ES/Kx2 Wide voltage range support Support of a wide voltage range of 2.7 to 5.5 V enables use for a broad range of applications. (RAM size: Bytes)		μPD70F3717 (32 K)	μPD70F3711 (20 K) μPD70F3722 (32 K)
256 K		μPD70F3704 (12 K) μPD70F3729 (12 K)	μPD70F3707 (12 K) μPD70F3716 (24 K) μPD70F3732 (16 K)	μPD70F3710 (12 K) μPD70F3721 (24 K) μPD70F3734 (16 K)
128 K	μPD70F3701 (6 K) μPD70F3726 (4 K)	μPD70F3703 (12 K) μPD70F3728 (6 K)	μPD70F3706 (12 K) μPD70F3715 (12 K) μPD70F3731 (6 K)	μPD70F3709 (12 K) μPD70F3720 (12 K) μPD70F3733 (6 K)
64 K	μPD70F3700 (6 K)	μPD70F3702 (12 K)		
Package	V850ES/HE2 V850ES/KE2  64-pin LQFP GB Thickness: 1.4 mm 10 x 10 mm Pitch: 0.5 mm	V850ES/KF2 V850ES/HF2  80-pin QFP GC Thickness: 1.4 mm 14 x 14 mm Pitch: 0.65 mm  80-pin TQFP GK Thickness: 1.0 mm 12 x 12 mm Pitch: 0.5 mm	V850ES/HG2 V850ES/JG2 V850ES/KG2 V850ES/JG2^{Note} V850ES/KG2  100-pin LQFP GC Thickness: 1.4 mm 14 x 14 mm Pitch: 0.5 mm  100-pin QFP GF Thickness: 2.7 mm 14 x 20 mm Pitch: 0.65 mm	V850ES/HJ2 V850ES/JJ2 V850ES/KJ2  144-pin LQFP GJ Thickness: 1.4 mm 20 x 20 mm Pitch: 0.5 mm

Note μPD70F3715, 70F3716, 70F3717 only

Remark The packages are shown in their actual size.

High performance

High performance that offers 29MIPS @ 20 MHz.
High performance goes far beyond enhancement of application functions.

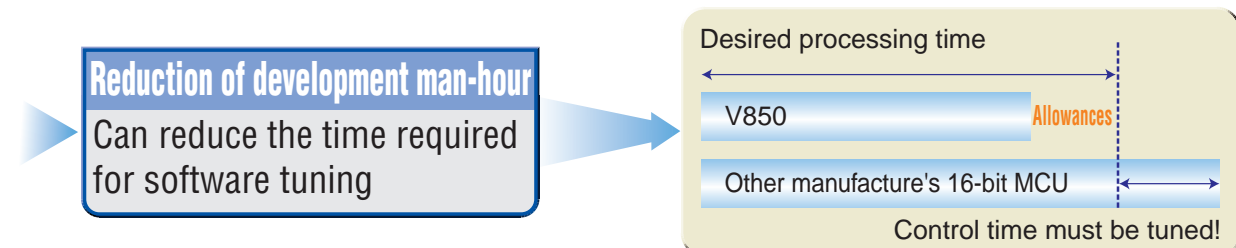
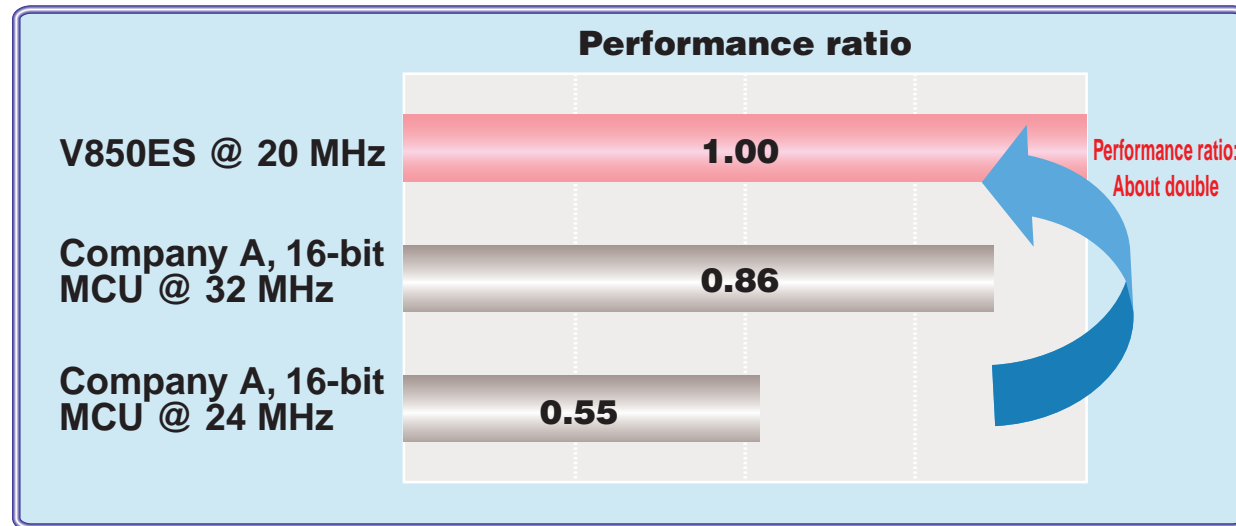

Thanks to high-performance, you are now free from the heavy burden of processing time tuning, which must be performed when using a conventional 16-bit microcontroller, allowing you efficient software development.

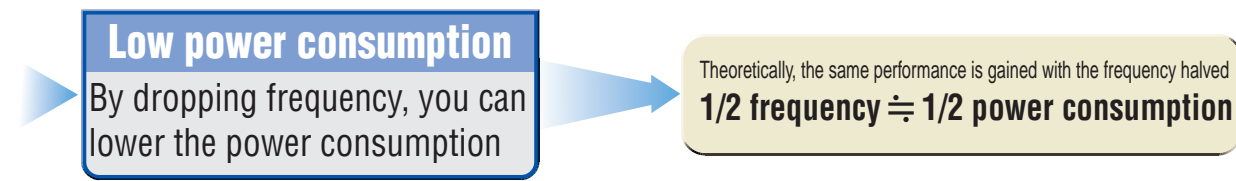

V850 can perform the same processing with a 16-bit microcontroller only with 1/2 to 1/3 of frequency, lowering the power consumption.

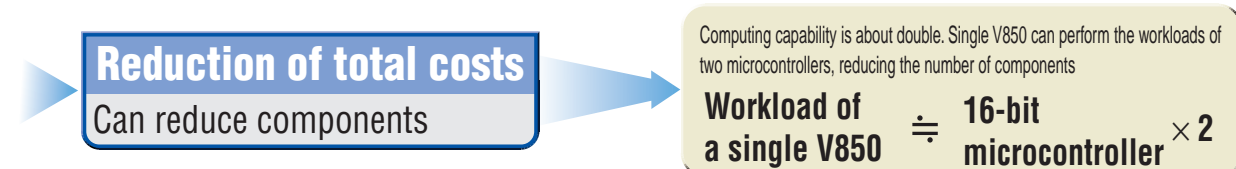

Due to its high computing capability, a single V850 can perform the workloads of about two 16-bit microcontrollers, reducing the number of components. As a result, it enables reduction of total cost.

High reliability

The reliability technologies developed for automotive flash microcontrollers can be found in all our flash microcontrollers, making them a safe choice.



A flash security setting function is provided to protect your software from malicious rewriting and reading.

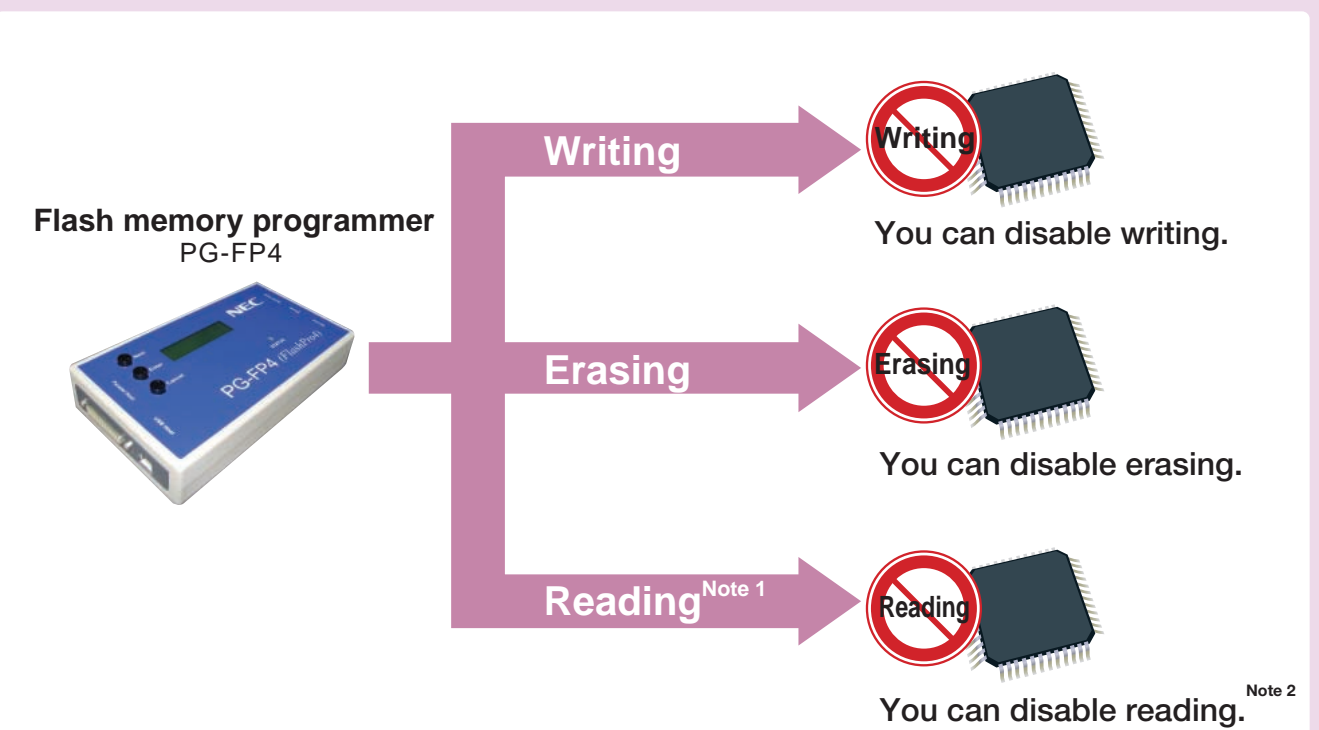

Notes 1. No commands for reading are provided for the V850ES/Jx2.
2. Reading is disabled by default in the PG-FP4.

Ripe environment for development

Various development environments for each development phase are available.

Lineup of development environment

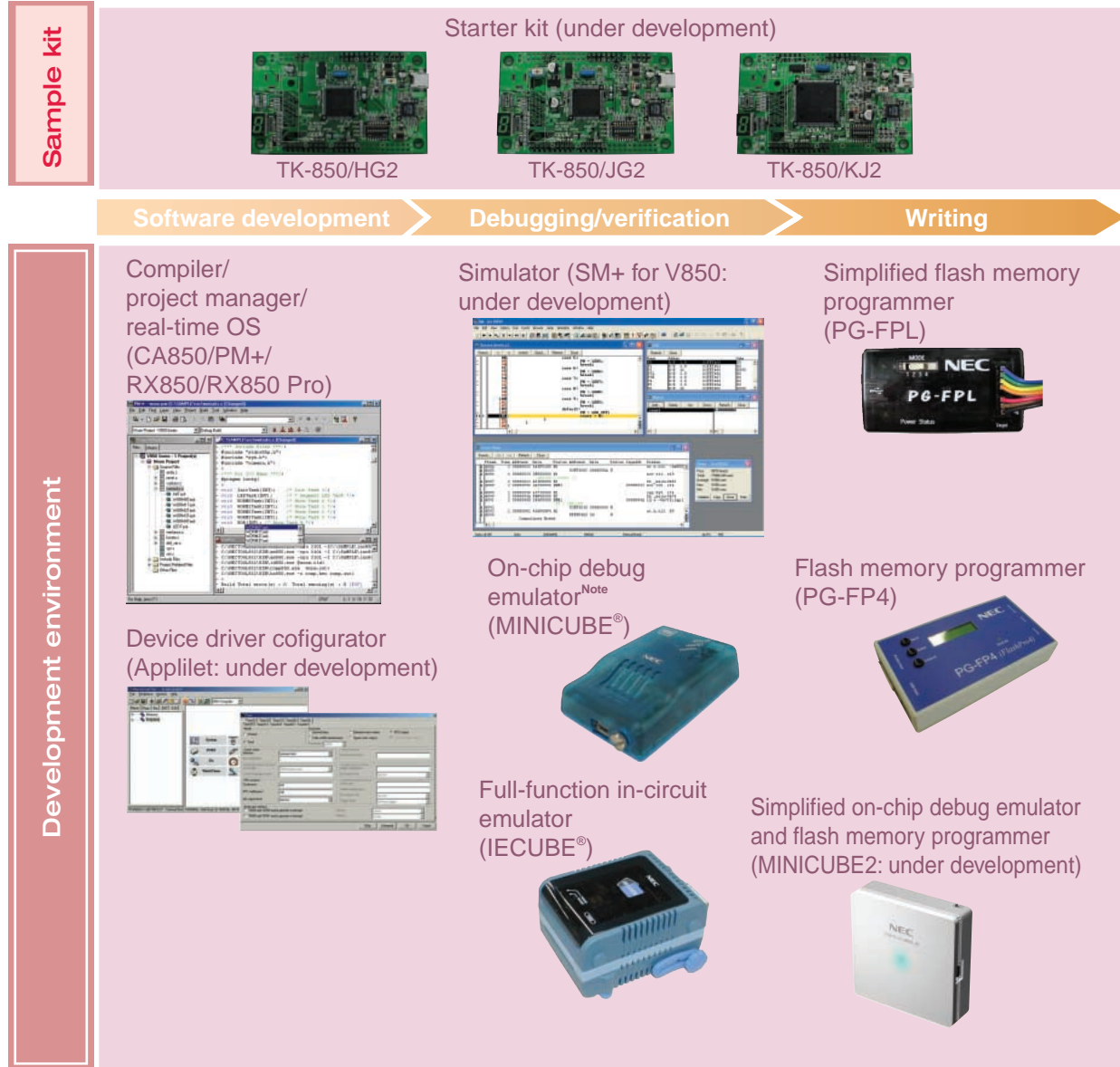

Note On-chip emulation of the V850ES/KE2, V850ES/KF2, and V850ES/KG2 using MINICUBE is not possible. Simple in-circuit emulation is possible for the V850ES/KE2, V850ES/KF2, and V850ES/KG2 using the self-check board included with these products.

"Significant man-hours are required to develop and modify software from existing chips". We propose developing environments to support such situations.

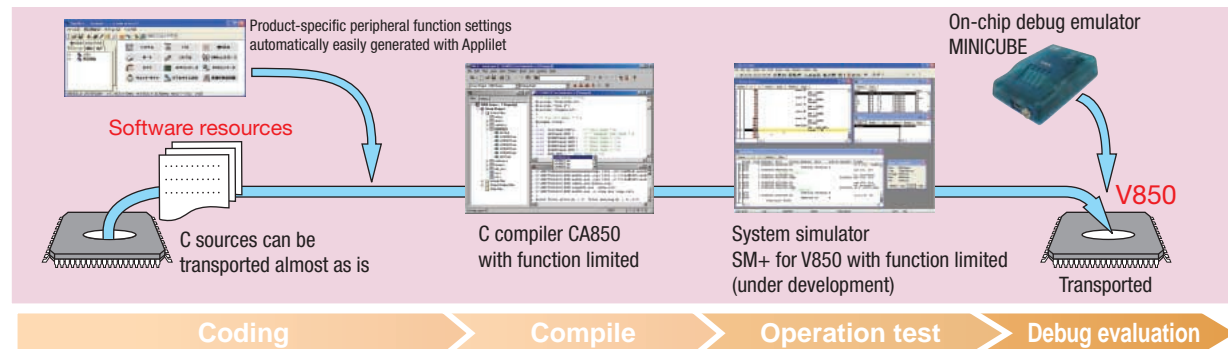

Support for mass production

Mass production support environment for your needs.

You can select the mass production method with the largest merit, according to delivery time or mass production quantity.

Programming by the customer

Delivery time^{Note 1}: Practically none, highly flexible

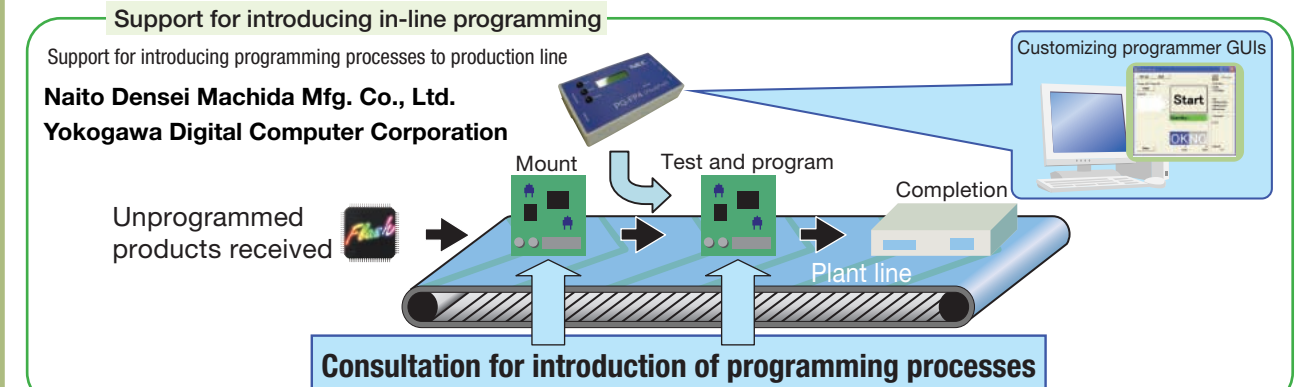

Flash memory programmers

Various products selectable for your purposes and price range



Programming by partner manufacturers

Flexible support for small-volume programming and short delivery time



Programmed products

Shipment form same as that of mask ROM microcontrollers

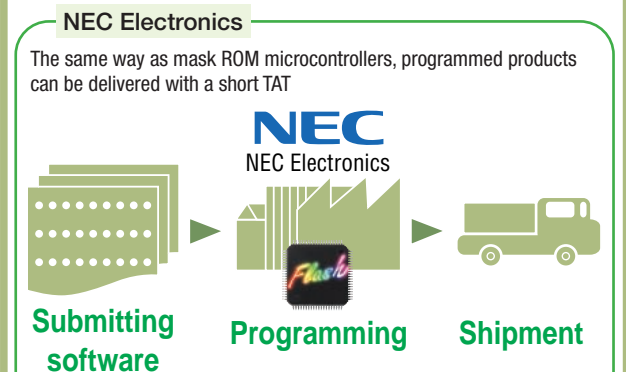

Programming houses

Delivery time^{Note 1}: Several days

NEC Electronics

Delivery time^{Note 1}: About 1/2 that of mask ROM^{Note 2}

Order All Flash microcontrollers

Order Conventional mask ROM microcontrollers

Delivery

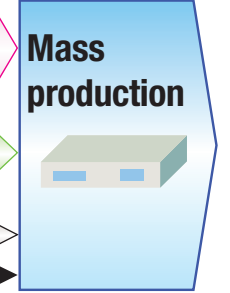

Notes 1. Period from completion of software until start of mass production

2. Delivery time may vary depending on purchase conditions, such as order quantity.

Product specifications

Item	V850ES/HE2		V850ES/HF2			V850ES/HG2		V850ES/HJ2				V850ES/JG2					V850ES/JJ2					V850ES/KE2		V850ES/KF2			V850ES/KG2			V850ES/KJ2			
	μPD70F3700	μPD70F3701	μPD70F3702	μPD70F3703	μPD70F3704	μPD70F3706	μPD70F3707	μPD70F3709	μPD70F3710	μPD70F3711	μPD70F3712	μPD70F3715	μPD70F3716	μPD70F3717	μPD70F3718	μPD70F3719	μPD70F3720	μPD70F3721	μPD70F3722	μPD70F3723	μPD70F3724	μPD70F3726	μPD70F3728	μPD70F3729	μPD70F3731	μPD70F3732	μPD70F3733	μPD70F3734					
CPU core	V850ES core		V850ES core			V850ES core		V850ES core				V850ES core					V850ES core					V850ES core		V850ES core			V850ES core			V850ES core			
CPU performance (Dhrystone)	29MIPS (@ 20 MHz)		29MIPS (@ 20 MHz)			29MIPS (@ 20 MHz)		29MIPS (@ 20 MHz)				29MIPS (@ 20 MHz)					29MIPS (@ 20 MHz)					29MIPS (@ 20 MHz)		29MIPS (@ 20 MHz)			29MIPS (@ 20 MHz)			29MIPS (@ 20 MHz)			
Flash memory (bytes)	64 K	128 K	64 K	128 K	256 K	128 K	256 K	128 K	256 K	376 K	512 K	128 K	256 K	384 K	512 K	640 K	128 K	256 K	384 K	512 K	640 K	128 K		128 K	256 K	128 K	256 K	128 K	256 K				
RAM (bytes)	6 K	6 K	12 K	12 K	12 K	12 K	12 K	12 K	12 K	20 K	20 K	12 K	24 K	32 K	40 K	48 K	12 K	24 K	32 K	40 K	48 K	4 K		6 K	12 K	6 K	16 K	6 K	16 K				
External bus interface	Bus type	—		—			Multiplexed				Separate/multiplexed					Separate/multiplexed					—		Multiplexed			Separate/multiplexed			Separate/multiplexed				
	Address bus	—		—			16-bit				22-bit					24-bit					—		16-bit			22-bit			24-bit				
	Data bus	—		—			8-bit/16-bit				8-bit/16-bit					8-bit/16-bit					—		8-bit/16-bit			8-bit/16-bit			8-bit/16-bit				
	Chip select signal	—		—			4				—					4					—		2			2			4				
Interrupt source	External	9		9			12		16		16		9					10					9		9			9			9		
	Internal	32		32			43		50		52		48					61					26		29			41			47		
Timer/counter	16-bit timer (TMQ)	Number of channels	1 ch		1 ch			2 ch		3 ch		1 ch					1 ch					—		—			—			—			
		Function	Interval timer/external event counter/3-phase PWM output/pulse width measurement/square-wave output/one-shot pulse output																														
	16-bit timer (TMP)	Number of channels	4 ch		4 ch			4 ch		4 ch		6 ch					9 ch					1 ch		1 ch			1 ch			1 ch			
		Function	Interval timer/external event counter/PWM output/pulse width measurement/square-wave output/one-shot pulse output																														
	16-bit timer (TMO)	Number of channels	—		—			—		—		—					—					1 ch		2 ch			4 ch			6 ch			
		Function	Interval timer/external event counter/PWM output/pulse width measurement/square-wave output/one-shot pulse output																														
	16-bit timer (TMM)	Number of channels	1 ch		1 ch			1 ch		1 ch		1 ch					1 ch					—		—			—			—			
		Function	Interval timer																														
	8-bit timer (TM5)	Number of channels	—		—			—		—		—					—					2 ch		2 ch			2 ch			2 ch			
		Function	Interval timer/external event counter/PWM output/square-wave output																														
8-bit timer (TMH)	Number of channels	—		—			—		—		—					—					2 ch		2 ch			2 ch			2 ch				
	Function	Interval timer/PWM output/carrier generator output/square-wave output																															
8-bit timer (BRG)	Number of channels	—		—			—		—		—					—					1 ch		1 ch			1 ch			1 ch				
	Function	Interval timer																															
Watch timer	1 ch		1 ch			1 ch		1 ch		1 ch		1 ch					1 ch					1 ch		1 ch			1 ch			1 ch			
Watchdog timer (WDT)	1 ch		1 ch			1 ch		1 ch		1 ch		1 ch					1 ch					2 ch		2 ch			2 ch			2 ch			
Serial interface	CSI	2 ch		2 ch			2 ch		3 ch		3 ch		3 ch					4 ch					2 ch		2 ch			1 ch			2 ch		
	CSI with automatic transmit/receive functions (32-byte buffer)	—		—			—		—		—		—					—					—		1 ch			2 ch			2 ch		
	UART	2 ch (LIN supported)		2 ch (LIN supported)			3 ch (LIN supported)		3 ch (LIN supported)		4 ch (LIN supported)		—					1 ch (LIN supported)					2 ch		2 ch			2 ch			2 ch		
	I²C	—		—			—		—		—		—					—					1 ch		1 ch			1 ch			1 ch		
	UART/CSI	—		—			—		—		—		1 ch (UART: LIN supported)					1 ch (UART: LIN supported)					—		—			1 ch			1 ch ^{Note}		
	UART/I²C	—		—			—		—		—		2 ch (UART: LIN supported)					2 ch (UART: LIN supported)					—		—			—			1 ch ^{Note}		
CSI/I²C	—		—			—		—		—		1 ch					1 ch					—		—			—			—			
A/D converter (10-bit)	10 ch		12 ch			16 ch		24 ch		12 ch		16 ch		8 ch					8 ch					8 ch		8 ch			8 ch			16 ch	
D/A converter (8-bit)	—		—			—		—		2 ch		2 ch		—					—					—		—			2 ch			2 ch	
DMA controller	—		—			4 ch (Transfer to/from: Internal peripherals, internal RAM)		4 ch (Transfer to/from: Internal peripherals, internal RAM, external memory)		4 ch (Transfer to/from: Internal peripherals, internal RAM, external memory)		4 ch (Transfer to/from: Internal peripherals, internal RAM, external memory)		4 ch (Transfer to/from: Internal peripherals, internal RAM, external memory)					4 ch (Transfer to/from: Internal peripherals, internal RAM, external memory)					—		—			4 ch (Transfer to/from: Internal peripherals, internal RAM, external memory)			4 ch (Transfer to/from: Internal peripherals, internal RAM, external memory)	
Port	I/O	51		67			84		128		84 (5 V tolerant= 40)		128 (5 V tolerant = 60)		43					59					76		112			112			
	Input	—		—			—		—		—		—					—					8		8			8			16		
On-chip debug function	Provided (RUN/break)		Provided (RUN/break)			Provided (RUN/break)		Provided (RUN/break)		Provided (RUN/break)		Provided (RUN/break)					Provided (RUN/break)					Provided (adapter supported, RUN/break)		Provided (adapter supported, RUN/break)			Provided (adapter supported, RUN/break)			Provided (RUN/break)			
Other peripheral I/O functions	On-chip POC/LVI, RAM hold flag		On-chip POC/LVI, RAM hold flag			On-chip POC/LVI, RAM hold flag		On-chip POC/LVI, RAM hold flag		On-chip POC/LVI, RAM hold flag		On-chip LVI, clock monitor, real-time output		On-chip LVI, clock monitor, real-time output					Real-time output					Real-time output			Real-time output			Real-time output			
Internal operating frequency	Main clock	16 to 20 MHz		16 to 20 MHz			16 to 20 MHz		16 to 20 MHz		2.5 to 20 MHz		2.5 to 20 MHz		2 to 20 MHz					2 to 20 MHz					2 to 20 MHz		2 to 20 MHz			2 to 20 MHz			
	Sub-clock (crystal resonator)	32.768 kHz		32.768 kHz			32.768 kHz		32.768 kHz		32.768 kHz		32.768 kHz		32.768 kHz					32.768 kHz					32.768 kHz		32.768 kHz			32.768 kHz			
	Internal oscillation clock	200 kHz (TYP.)		200 kHz (TYP.)			200 kHz (TYP.)		200 kHz (TYP.)		200 kHz (TYP.)		200 kHz (TYP.)		200 kHz (TYP.)					200 kHz (TYP.)					—		—			—			
Power supply voltage	3.5 to 5.5 V (A/D converter: 4.0 to 5.5 V)		3.5 to 5.5 V (A/D converter: 4.0 to 5.5 V)			3.5 to 5.5 V (A/D converter: 4.0 to 5.5 V)		3.5 to 5.5 V (A/D converter: 4.0 to 5.5 V)		2.85 to 3.6 V		2.85 to 3.6 V		2.7 to 5.5 V					2.7 to 5.5 V					2.7 to 5.5 V		2.7 to 5.5 V			2.7 to 5.5 V				
Package	64-pin LQFP (10 × 10 mm)		80-pin TQFP (12 × 12 mm)			100-pin LQFP (14 × 14 mm)		144-pin LQFP (20 × 20 mm)		•100-pin LQFP (14 × 14 mm) •100-pin QFP (14 × 20 mm)		100-pin LQFP (14 × 14 mm)		144-pin LQFP (20 × 20 mm)					64-pin LQFP (10 × 10 mm)					80-pin QFP (14 × 14 mm)			•100-pin LQFP (14 × 14 mm) •100-pin QFP (14 × 20 mm)			144-pin LQFP (20 × 20 mm)			
Operating ambient temperature	-40°C to +85°C		-40°C to +85°C			-40°C to +85°C		-40°C to +85°C		-40°C to +85°C		-40°C to +85°C		-40°C to +85°C					-40°C to +85°C					-40°C to +85°C		-40°C to +85°C			-40°C to +85°C			-40°C to +85°C	

Note This UART is shared by I²C and CSI. Three UART channels are provided in the V850ES/KJ2.

Software

- Rich lineup of tools for each development phase

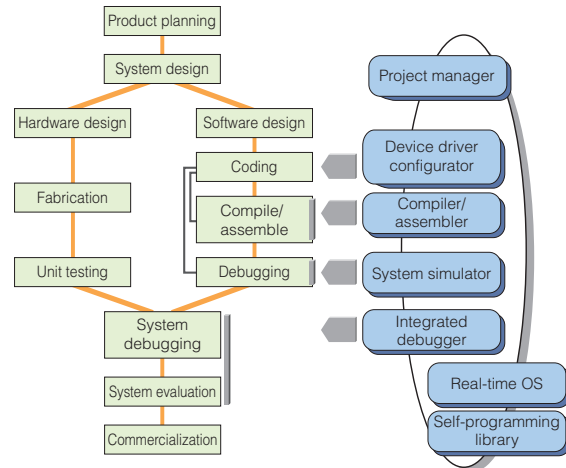

Type	Name
Software package	SP850
Project manager	PM+
C compiler	CA850
System simulator	SM+ for V850 (under development)
Integrated debugger	ID850QB
Real-time OS	RX850, RX850 Pro
Self-programming library	—
Device driver configurator	Appilet (under development)

- Software package**
Project manager, C compiler, assembler, system simulator, integrated debugger, etc., provided on a single CD-ROM disk
- Project manager**
• Various development tools integrated on Windows™
• A series of operations, such as editor, builder, and debugger startup, is possible.
- C compiler**
• ANSI-C standard compliant
• Powerful optimization function
• Optimum functions for embedded system development
• Multiple utilities
- System simulator**
• GUI design similar to that of integrated debugger
• Evaluation possible without target prior to target completion
- Integrated debugger**
• Operates on Windows
• Easy to understand and use GUI (Graphical User Interface)
• Buttons provided for frequently used commands
• Can be started up with a simple mouse click
- Real-time OS**
• μITRON 3.0 specification compliant
• Compact size
• Easy program reuse and maintenance
- Self-programming library**
• The flash memory can be programmed with the microcontroller itself, without using a programmer.
• Built-in boot swap function for protecting the boot area at power down
- Device driver configurator (under development)**
The setting sources of the built-in peripheral functions can be automatically generated through GUI operation without referring to the device's user's manual.

Hardware

Full-function in-circuit emulator (IECUBE)

- Enables detailed debugging through equivalent emulation of microcontrollers, using trace, time measurement, and other functions.

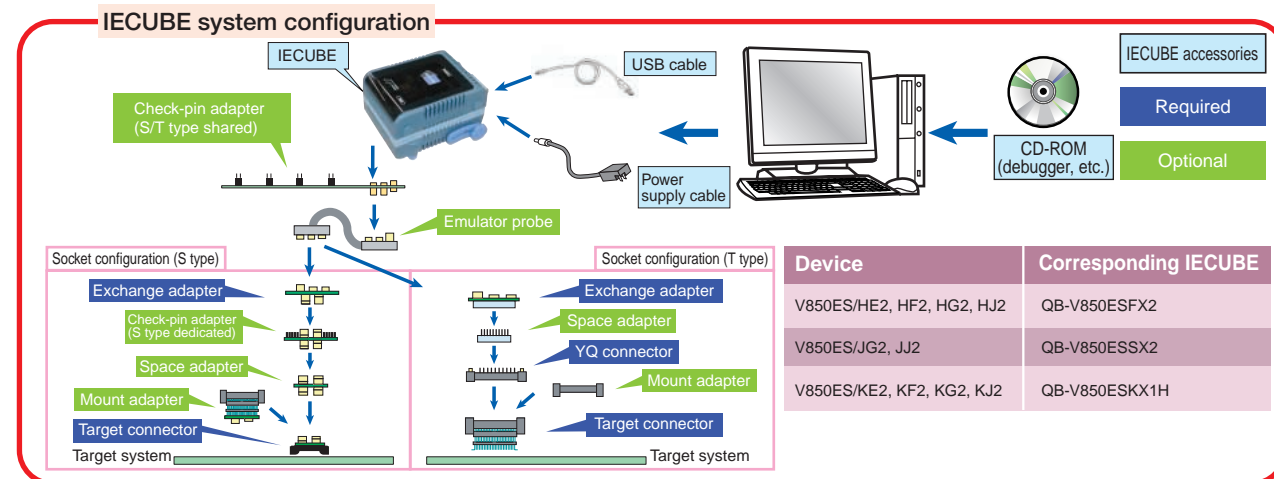

On-chip debug emulator (MINICUBE)

- Debugging with the microcontroller mounted on the target system is possible.
- Basic debugging functions such as run break and download are provided.

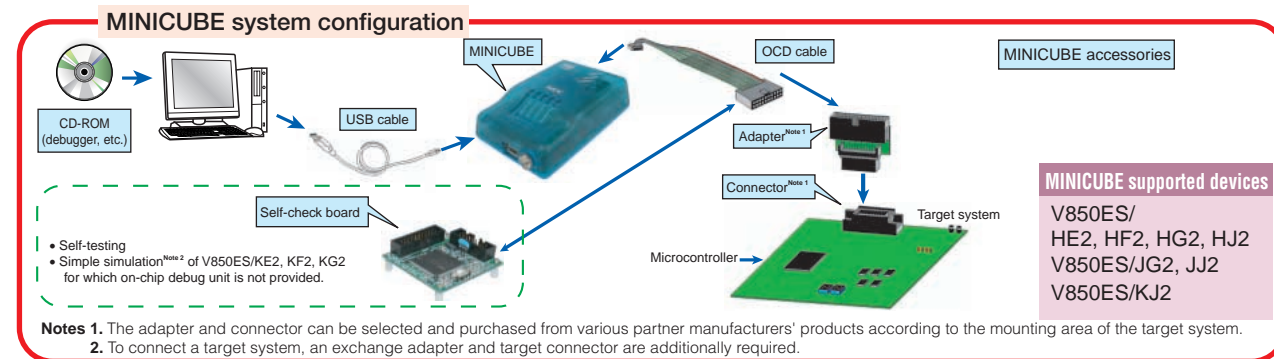

Simplified on-chip debug emulator & flash memory programmer (MINICUBE2: Under development)

- Debugging with the microcontroller mounted on the target system is possible.
- In addition to simple debugging with a foreground monitor, use as a programmer is also possible.



List of Partner Companies (listed in no particular order)

Matsubara.K Corporation
<http://www.mtbrk.com>

Synchro-work Corporation
http://www.synchro.co.jp/en/index_en.html

Liberty Corporation
<http://www.liberty-rom.com>

ROMTEC.Inc
<http://www.romtec.co.jp>

ARROW Electronics (UK) Ltd
<http://www.arrowne.com>

Gleichmann & Co. Electronics GmbH
<http://www.msc.de>

MSC Vertriebs GmbH
<http://www.msc.de>

ertec GmbH
<http://www.ertec.de>

Source Electronics Corporation
<http://www.soucee.com>

Telford Industries Pte Ltd
<http://www.telfordgp.com>

Naito Densai Machida Mfg. Co., Ltd.
<http://www.ndk-m.co.jp/asmis/eng>

Yokogawa Digital Computer Corporation
<http://www.yokogawa-digital.com/emb/en/>

Wave Technology Co., Ltd.
http://www.y1000.com/index_e.html

Application Corporation
http://www.apply.co.jp/index_eng.html

Interface Co., Ltd.
<http://www.itf.co.jp>

Forward Electric Co., Ltd.
<http://www.forward-china.com>

Caution μ PD70F3726, 70F3728, 70F3729, 70F3731, 70F3732, 70F3733, and 70F3734 use SuperFlash[®] under license from Silicon Storage Technology, Inc.

IECUBE and MINICUBE are registered trademarks of NEC Electronics Corporation in Japan and Germany.

Windows is either a registered trademark or trademark of Microsoft Corporation in the United States and/or other countries.

SuperFlash is a registered trademark of Silicon Storage Technology, Inc. in several countries including the United States and Japan.

The names of other companies and products are the registered trademarks or trademarks of their companies.

- The information in this document is current as of October, 2005. The information is subject to change without notice. For actual design-in, refer to the latest publications of NEC Electronics data sheets or data books, etc., for the most up-to-date specifications of NEC Electronics products. Not all products and/or types are available in every country. Please check with an NEC Electronics sales representative for availability and additional information.
- No part of this document may be copied or reproduced in any form or by any means without the prior written consent of NEC Electronics. NEC Electronics assumes no responsibility for any errors that may appear in this document.
- NEC Electronics does not assume any liability for infringement of patents, copyrights or other intellectual property rights of third parties by or arising from the use of NEC Electronics products listed in this document or any other liability arising from the use of such products. No license, express, implied or otherwise, is granted under any patents, copyrights or other intellectual property rights of NEC Electronics or others.
- Descriptions of circuits, software and other related information in this document are provided for illustrative purposes in semiconductor product operation and application examples. The incorporation of these circuits, software and information in the design of a customer's equipment shall be done under the full responsibility of the customer. NEC Electronics assumes no responsibility for any losses incurred by customers or third parties arising from the use of these circuits, software and information.
- While NEC Electronics endeavors to enhance the quality, reliability and safety of NEC Electronics products, customers agree and acknowledge that the possibility of defects thereof cannot be eliminated entirely. To minimize risks of damage to property or injury (including death) to persons arising from defects in NEC Electronics products, customers must incorporate sufficient safety measures in their design, such as redundancy, fire-containment and anti-failure features.
- NEC Electronics products are classified into the following three quality grades: "Standard", "Special" and "Specific".
The "Specific" quality grade applies only to NEC Electronics products developed based on a customer-designated "quality assurance program" for a specific application. The recommended applications of an NEC Electronics product depend on its quality grade, as indicated below. Customers must check the quality grade of each NEC Electronics product before using it in a particular application.
 - "Standard": Computers, office equipment, communications equipment, test and measurement equipment, audio and visual equipment, home electronic appliances, machine tools, personal electronic equipment and industrial robots.
 - "Special": Transportation equipment (automobiles, trains, ships, etc.), traffic control systems, anti-disaster systems, anti-crime systems, safety equipment and medical equipment (not specifically designed for life support).
 - "Specific": Aircraft, aerospace equipment, submersible repeaters, nuclear reactor control systems, life support systems and medical equipment for life support, etc.

The quality grade of NEC Electronics products is "Standard" unless otherwise expressly specified in NEC Electronics data sheets or data books, etc. If customers wish to use NEC Electronics products in applications not intended by NEC Electronics, they must contact an NEC Electronics sales representative in advance to determine NEC Electronics' willingness to support a given application.

(Note)

- (1) "NEC Electronics" as used in this statement means NEC Electronics Corporation and also includes its majority-owned subsidiaries.
- (2) "NEC Electronics products" means any product developed or manufactured by or for NEC Electronics (as defined above).

For further information,
please contact:

NEC Electronics Corporation
1753, Shimonumabe, Nakahara-ku,
Kawasaki, Kanagawa 211-8668,
Japan
Tel: 044-435-5111
<http://www.necel.com/>

[America]

NEC Electronics America, Inc.
2880 Scott Blvd.
Santa Clara, CA 95050-2554, U.S.A.
Tel: 408-588-6000
800-366-9782
<http://www.am.necel.com/>

[Europe]

NEC Electronics (Europe) GmbH
Arcadiastrasse 10
40472 Düsseldorf, Germany
Tel: 0211-65030
<http://www.eu.necel.com/>

Hanover Office
Podbielskistrasse 164
30177 Hannover
Tel: 0 511 33 40 2-0

Munich Office
Werner-Eckert-Strasse 9
81829 München
Tel: 0 89 92 10 03-0

Stuttgart Office
Industriestrasse 3
70565 Stuttgart
Tel: 0 711 99 01 0-0

United Kingdom Branch
Cygnus House, Sunrise Parkway
Linford Wood, Milton Keynes
MK14 6NP, U.K.
Tel: 01908-691-133

Succursale Française
9, rue Paul Dautier, B.P. 52180
78142 Velizy-Villacoublay Cédex
France
Tel: 01-3067-5800

Sucursal en España
Juan Esplandiú, 15
28007 Madrid, Spain
Tel: 091-504-2787

Tyskland Filial
Täby Centrum
Entrance S (7th floor)
18322 Täby, Sweden
Tel: 08 638 72 00

Filiale Italiana
Via Fabio Filzi, 25/A
20124 Milano, Italy
Tel: 02-667541

Branch The Netherlands
Limburglaan 5
5616 HR Eindhoven
The Netherlands
Tel: 040 265 40 10

[Asia & Oceania]

NEC Electronics (China) Co., Ltd
7th Floor, Quantum Plaza, No. 27 ZhiChunLu Haidian
District, Beijing 100083, P.R.China
TEL: 010-8235-1155
<http://www.cn.necel.com/>

NEC Electronics Shanghai Ltd.
Room 2509-2510, Bank of China Tower,
200 Yincheng Road Central,
Pudong New Area, Shanghai P.R. China P.C:200120
Tel: 021-5888-5400
<http://www.cn.necel.com/>

NEC Electronics Hong Kong Ltd.
12/F., Cityplaza 4,
12 Taikoo Wan Road, Hong Kong
Tel: 2886-9318
<http://www.hk.necel.com/>

Seoul Branch
11F., Samik Lavied'or Bldg., 720-2,
Yeoksam-Dong, Kangnam-Ku,
Seoul, 135-080, Korea
Tel: 02-558-3737

NEC Electronics Taiwan Ltd.
7F, No. 363 Fu Shing North Road
Taipei, Taiwan, R. O. C.
Tel: 02-2719-2377

NEC Electronics Singapore Pte. Ltd.
238A Thomson Road,
#12-08 Novena Square,
Singapore 307684
Tel: 6253-8311
<http://www.sg.necel.com/>



Document No. U17725EJ2V0PF00 (2nd edition)
Date Published December 2005 N CP(K)

© NEC Electronics Corporation 2005