

1. Scope

This document describes the design and use of the MLX10803 evaluation board. For a general description about the functionality of the MLX10803 please refer to the MLX10803 data sheet.

Note: Evaluation boards produced before Q1 2006 use the MLX10803A. Some resistor values and corresponding parameters differ from the circuit presented in this document. Please consult the MLX10803 internet product page at <http://www.melexis.com> for the latest updates.

2. Applications

The MLX10803 evaluation board is intended to be used as an application example of the MLX10803 Power LED driver. It was developed to demonstrate the features of the circuit and is suitable to be used in prototypes and mock ups to allow quick implementation of the MLX10803 in a LED lighting application.

3. Other Components Needed

LED(s): - all High Brightness LEDs, e.g.:

- Lumileds Luxeon[®], Lumileds Luxeon III
- Cree XLamp[™] 3 7090 series, Cree XLamp[™] 7090 series
- OSRAM (Advanced) Power TOPLED[®], OSRAM Golden Dragon[®]
- Nichia POWER LED Series

Optional NTC: - external temperature sensor

- Standard NTC thermistor with $R_{T=25^{\circ}\text{C}} = 100\text{k}\Omega..470\text{k}\Omega$

4. Application Circuit

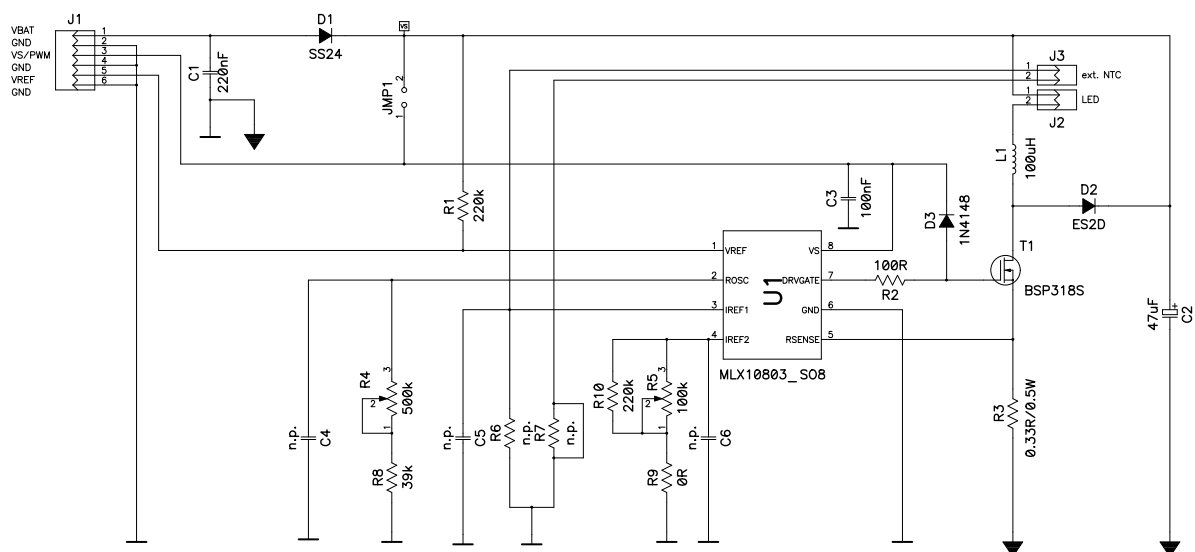

Figure 1: Evaluation board schematic

5. Connector Pin Definitions

Connector J1 (Supply)	Signal	Connection
Pin1	VBAT	general load and IC supply, 6..32V DC
Pin2	GND	supply ground
Pin3	VS/PWM	Separate IC supply for PWM usage
Pin4	GND	Additional ground for VS/PWM signal
Pin5	VREF	Voltage reference input VREF
Pin6	GND	Additional ground for VREF signal
Connector J2 (LED)	Signal	Connection
Pin1	LED+	High Brightness LED(s) anode
Pin2	LED-	High Brightness LED(s) cathode
Connector J3 (NTC)	Signal	Connection
Pin1	Ext. NTC	External NTC for temperature down regulation
Pin2	Ext. NTC	

Note: signals in **bold** are compulsory

6. PCB Layout

J1 Pinout (Supply)

Pin1	VBAT
Pin2	GND
Pin3	VS/PWM
Pin4	GND
Pin5	VREF
Pin6	GND

J3 Pinout (NTC)

Pin1	external NTC
Pin2	external NTC

J2 Pinout (LED)

Pin1	LED(s)+ (anode)
Pin2	LED(s)- (cathode)

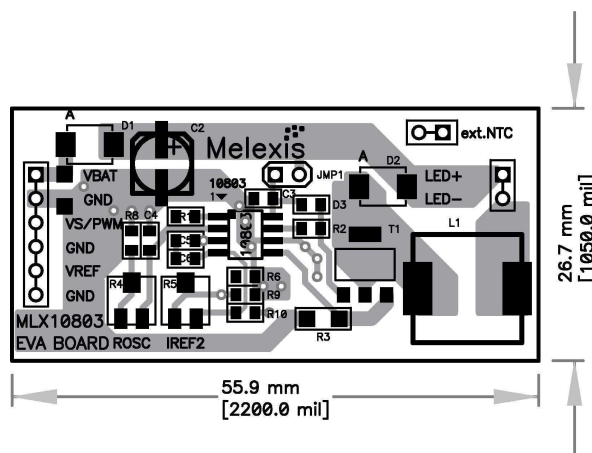

Figure 2: Evaluation board dimensions and locations

7. Minimal Board Connections

For normal operation only a few connections are necessary. The supply line VBAT must be connected to any standard DC supply. The input voltage should always be about 2V higher than the sum of all LED forward voltages in order to keep the regulator working. The supply must be able to drive the peak LED current that is defined with the IREF2 potentiometer.

The LED(s) is (are) connected to the board via a polarised plug to avoid incorrect connection.

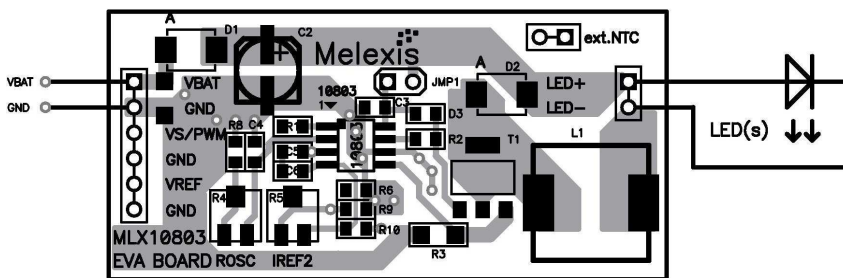

Figure 3: Minimal board connections

8. Description

For details on the function of the LED driver circuit, please refer to the MLX10803 IC specification.

8.1. General

For standard applications without the use of PWM, the jumper JMP1 has to be set in order to supply the IC directly from the VBAT line. This is the default setting.

The LED(s) must be connected to J2, anode to LED+ (Pin1) and cathode to LED- (Pin2).

Supply voltage (6..32V DC) is applied to J1, Pin1 while Pin2 is the corresponding GND connection.

The sense resistor R3 was selected in order to limit the maximum peak current to about 2 Ampere. That was done to remain within the operation area (saturation current I_{sat}) of the selected coil. Thus, the average LED current is limited to values about 1.5 Ampere depending on the used settings. If higher currents are desired, care has to be taken with the selection of coil and transistor and attention has to be drawn to the thermal behaviour of the board.

8.2. Using PWM

Dimming the average LED current is achieved by applying a PWM signal to the VS/PWM pin (J1, Pin3). In fact, the IC is powered on and off according to the state of the duty cycle. Because of the maximum IC settling time, the maximum PWM frequency is limited to 5kHz. The on voltage of the PWM signal must be 6..32V in order to power the IC correctly. The PWM signal must be able to drive the IC's supply current which is maximum 700µA @13.8V and 2mA @32V.

In PWM mode, the jumper JMP1 must be removed to open the connection to VBAT!
Please note that there is no polarity protection in the PWM line! The user has to ensure the correct polarity of the PWM signal!

8.3. Using the VREF input as a second peak current threshold level

The VREF input is intended to be used to set an optional voltage reference for the RSENSE peak current threshold level. It acts in the same way as IREF1 and IREF2 inputs but has no internal pull up current sources. Thus, the voltage at VREF must be applied from extern. If the voltage level at VREF becomes lower then the voltages on IREF1 and IREF2, this voltage becomes dominant and is used (divided by 5) as the RSENSE current threshold level. With that feature, it is possible to have a 2nd LED current/light output as it is used for example in combined tail/break lights.

Whether this pin is an analogue input, it can also be used as an alternative, digital PWM input. The user has to ensure that the voltage level during the ON state is higher then the dominant level on pins IREF1/IREF2. As the highest possible voltage on both IREF pins can be 3.8V, a PWM signal with a signal amplitude of 5V (standard logic or μ C output) is best suited.

Furthermore, the OFF time signal amplitude has to be < 20mV, as any higher level on that pin is interpreted as voltage input level and used for setting the RSENSE current threshold level.

As default, the VREF pin is externally pulled up to VS by a 470k resistor. This way, the VREF pin is always recessive ("H") in case it is not used.

8.4. Using an external NTC as temperature sensor

In order to avoid destruction of the LED(s) due to overheating, the MLX10803 offers the possibility for a temperature down regulation. Via connector J3, a NTC resistor can be connected as a temperature sensor. For best results, the NTC should be thermally connected to the LED(s).

The NTC is connected to the IREF2 Pin of the MLX10803. For a quick adaptation to a certain application, the PCB consists of two unpopulated 0805 pads for a serial and a parallel resistor (R6, R7). With these resistors, the regulation starting point can be manipulated as desired. As default, the pad for the series resistor (R7) is shortcut by a thin PCB trace. If a series resistor should be used, this trace has to be cut off before it is populated.

If temperature down regulation should be used, the parameters *monoflop time* (by potentiometer R4, ROSC) and *LED peak current* (by potentiometer R5, IREF2) have to be adjusted first.

The voltage on pin IREF2 is measured and taken as a reference to define the starting point for the temperature down regulation.

The voltage on pin IREF1, that is defined by the resistance of the NTC (together with the optionally used R6/R7), must have the same voltage level as IREF2 at the corner temperature, where the down regulation starts to work. So, the overall resistance of IREF1 is similar to the resistance on pin IREF2 at that corner temperature.

For a better illustration, an example is given below:

$$R_{IREF2} = 47k\Omega$$

$$T_{Start} = 85^{\circ}C$$

$$V_{IREF2} = I_{REF2} \cdot R_{IREF2} = 50\mu A \cdot 47k\Omega = 2.35V$$

$$V_{IREF1} = 2.35V @ T_{Start} \rightarrow R_{IREF1(T=85^{\circ}C)} = 47k\Omega$$

NTC selection according to the corresponding NTC datasheet. A standard NTC (e.g. BC components, part no. 2322 640 55474) with a nominal value of:

$$R_{NTC(T=25^{\circ}C)} = 470k\Omega \text{ was selected.}$$

It has a resistance of:

$$R_{NTC(T=85^{\circ}C)} = 36.05k\Omega \text{ at } T=85^{\circ}C.$$

To get the 47kΩ on IREF1 at T=85°C, a resistor of:

$$R_{IREF1} = R_{NTC(T=85^{\circ}C)} + R7$$

$$R7 = R_{IREF1} - R_{NTC(T=85^{\circ}C)} = 47k\Omega - 36.05k\Omega$$

$$R7 = 10.95k\Omega$$

has to be added in series to the NTC.

With this selection, $R_{NTC(T=25^{\circ}C)} = 470k\Omega$ and $R7 = 10.95k\Omega$, the temperature regulation starts from $T_{amb} = 85^{\circ}C$. If the temperature increases further, the resistance of the NTC drops even more and lowers the voltage on IREF1. This way, the current threshold level at RSENSE is lowered which results in a lower peak current and thus, a lower average LED current. Less current through the LED(s) generate less heat which increases the NTCs resistance again: the current threshold level at RSENSE is increased and as a consequence, the average LED current rises again. Depending on the thermal design and the ambient temperatures of the module, the regulation works faster or slower around the adjusted corner temperature point.

The following schematic shows the connection of an external temperature sensor to the EVB10803:

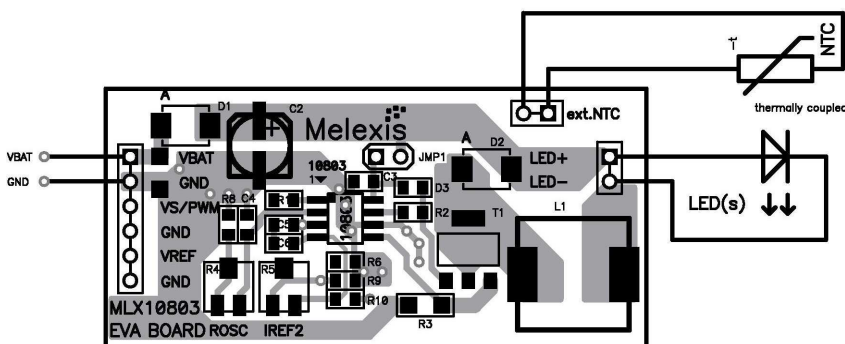

Figure 4: External NTC for temperature down regulation

9. Used Components

Board Part Number	Type	Category	Part Name (Manufacturer)	Alternative Part(s) (Manufacturer)	Data Sheet Download
D1	Rectifier	Schottky Diode	SS24 (FCH)	many	www.fairchildsemiconductor.com
D2	Rectifier	Ultrafast Recovery	ES2D (FCH)	many, e.g. BYD77 (PHI)	www.fairchildsemiconductor.com
D3	Diode	Switching Diode	MCL4148	many	www.vishay.com
T1	Switching Transistor	n-channel MOSFET	BSP318S (INF)	many, e.g. NTF3055 (ON)	www.infineon.com
L1	Inductor	Power choke	WE-PD 100µH (WE)	many, e.g. MSS1260-104ML (CC)	www.wuerth-elektronik.de
C1	Capacitor 220nF/50V	Ceramics, X7R, 1206 type	B37941 (EP)	many	www.epcos.com
C2	Capacitor 47µF/35V	Electrolytic, low ESR	EEEFK1V470P (PS)	many	www.panasonic.com/industrial
C3	Capacitor 100nF/50V	Ceramics, X7R, 0805 type	B37941 (EP)	many	www.epcos.com
C4, C5, C6	Capacitor	Ceramics, X7R, 0805 type	Not populated by default, to be populated on demand by customer		
R1, R2, R8, R9, R10	Resistors 5% tolerance	0805 type	D12CRCW (VS)	many	www.vishay.com
R3	Resistor 0.33Ω/0.5W 1% tolerance	1206 type	LR1206-R33FI (WW)	many	www.welwyn-tt.co.uk
R4	Potentiometer 500k/0.25W, 20% tolerance	Trimming-Potentiom.	Bourns 3314	many	www.bourns.com
R5	Potentiometer 100k/0.25W, 20% tolerance	Trimming-Potentiom.	Bourns 3314	many	www.bourns.com
R6, R7	Resistor	0805 type	Not populated by default, to be populated on demand by customer		

manufacturer codes:

FCH = Fairchild Semiconductor
WE = Würth Elektronik
INF = Infineon
YG = Yageo

PHI = Philips Semiconductor
VS = Vishay
CC = Coilcraft
WW = Welwyn

PS = Panasonic
ON = On Semiconductor
EP = Epcos

10. EMI Measurement of the EVB10803

The EVB10803 is designed for a good electromagnetic emission behaviour. Please refer to the MLX10803 IC specification as well as to the available application notes for general EMC considerations. The test was performed on the original evaluation board and the settings shown below. No additional filter components had been used. The conducted electromagnetic emission measurement was accomplished according to IEC 61967 part 4. The RF was decoupled from line VBAT.

Settings EVB10803:

$V_{BAT} = 13.5V$
 LED: Luxeon III @ $I_{LED} = 350mA$
 $R_{IREF2} = 25k\Omega$
 $R_{ROSC} = 390k\Omega \rightarrow f_{sw(13.5V)} = 34\text{ kHz}$

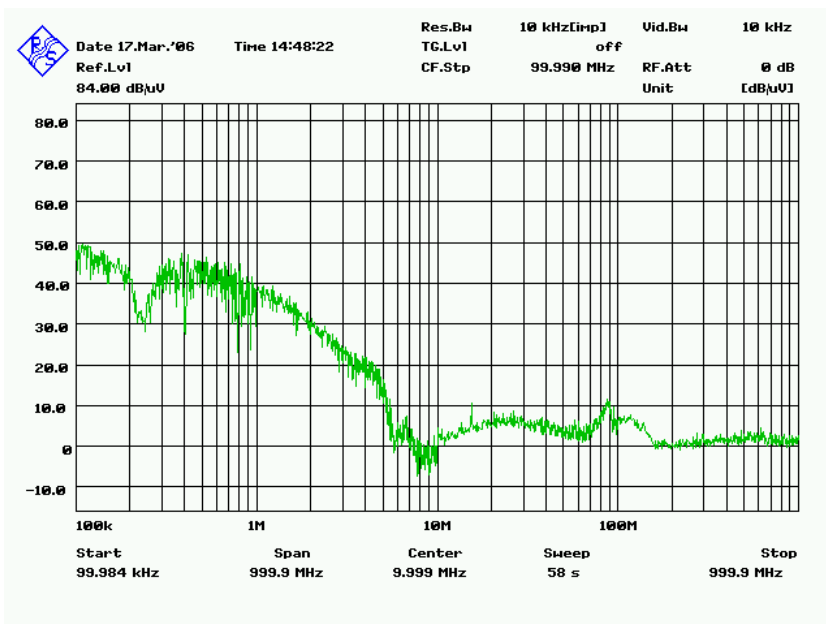

Figure 6: Conducted electromagnetic emission EVB10803

11. Conclusion

The MLX10803 evaluation board was designed to provide an easy solution for demonstrating the use of high brightness LEDs in conjunction with the MLX10803 LED driver chip. It is suitable to be driven under automotive supply conditions (12V board systems) and is optimized in terms of electromagnetic emission behaviour to be able to fulfill automotive standards.

If good emission behaviour is not an issue (e.g. industrial/consumer applications), smaller caps (for C1/C2) as well as an unshielded coil can be used. Thus, size and cost can be reduced once more.

For the latest version of this document, go to our website at:

www.melexis.com

Or for additional information contact Melexis Direct:

Europe and Japan:

Phone: +32 13 61 16 31
E-mail: sales_europe@melexis.com

All other locations:

Phone: +1 603 223 2362
E-mail: sales_usa@melexis.com

QS9000, VDA6.1 and ISO14001 Certified