

**Broadband Driver Amplifier
50 to 3300 MHz**

MAAM-007866-0P1R00

V1

Features

- High Gain: 27 dB (TYP.)
- Flat Broadband Gain Response: +/- 1.2 dB (TYP)
- P1dB: +23.0 dBm (TYP.)
- Flexibility for Multi-Band Systems
- On-Chip Active Bias Network
- Lead Free 3 mm PQFN Surface Mount Package
- 260°C Reflow Capability

Applications

- LO Buffer Amplifier
- Driver Stage for Power Amplifiers
- Basestation / Repeater Applications
- Broadband RF Gain Block

Description

M/A-COM's MAAM-007866-0P1R00 amplifier utilizes GaAs HBT technology with an +18 Volt BV_{ceo} process for improved linearity performance, power efficiency, and high reliability, in a low cost 3 mm PQFN surface mount plastic package.

The MAAM-007866-0P1R00 incorporates an on-chip active bias network for ease of implementation, and maintains high linearity over temperature. This 2 stage high gain design operates from a single +5 volt supply and has a +5 volt reference pin for power down control capability

The MAAM-007866-0P1R00 requires a minimal number of external components to achieve a flat gain response across the entire 50 to 3300 MHz frequency band.

Ordering Information¹

Part Number	Package
MAAM-007866-0P1R00	3 mm 12 lead PQFN
MAAM-007866-0P1RA1	Sample Application Kit
MAAM-007866-0P1RTR	1000 Piece Tape & Reel

1. Reference Application Note M513 for reel size information.

Product Image

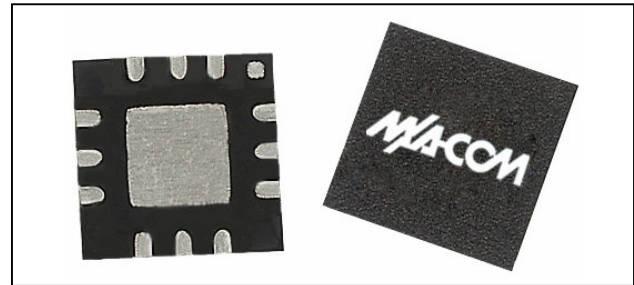

Functional Block Diagram

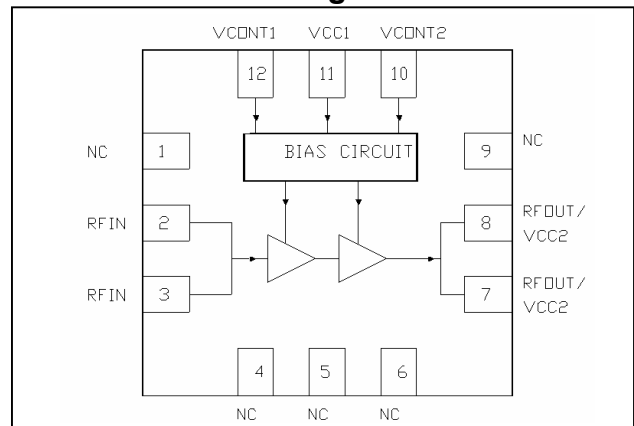

Pin Configuration

Pin No.	Function	Description
1	No Connection	No connection
2	RF Input	RF Input Signal. External circuit required for optimum performance
3	RF Input	RF Input Signal. External circuit required for optimum performance
4	No Connection or GND	No Connection. GND preferred
5	No Connection or GND	No Connection. GND preferred
6	No Connection or GND	No Connection. GND preferred
7	RF Output / VCC2	RF Output & 2nd Stage VCC Supply Input External circuit required for optimum performance
8	RF Output / VCC2	RF Output & 2nd Stage VCC Supply Input External circuit required for optimum performance
9	No Connection	No Connection
10	VCONT2	DC Control Input to 2nd Stage Bias circuit. External resistor required for normal operation @ 5V. Can be combined with VCONT1.
11	VCC1	VCC Supply to 1st Stage. Bypass Capacitor value & location is critical. Must be as close to the pin as possible. See Eval Board Layout.
12	VCONT1	DC Control Input to 1st Stage Bias circuit. See application circuit.
Pkg Base	GND	RF/DC GND and thermal Path to PCB Vias. Sufficient Vias must be provided for thermal considerations. See PCB Layout

M/A-COM Inc. and its affiliates reserve the right to make changes to the product(s) or information contained herein without notice. M/A-COM makes no warranty, representation or guarantee regarding the suitability of its products for any particular purpose, nor does M/A-COM assume any liability whatsoever arising out of the use or application of any product(s) or information.

• **North America** Tel: 800.366.2266 / Fax: 978.366.2266
 • **Europe** Tel: 44.1908.574.200 / Fax: 44.1908.574.300
 • **Asia/Pacific** Tel: 81.44.844.8296 / Fax: 81.44.844.8298

Visit www.macom.com for additional data sheets and product information.

**Broadband Driver Amplifier
50 to 3300 MHz**

MAAM-007866-0P1R00

V1

Electrical Specifications¹: Tc= +25°C, VCONT= 5 V, VCC = 5 V, Z₀ = 50 Ω, CW

Parameter	Test Conditions	Units	Min	Typ	Max
Frequency Range		MHz	50		3300
Gain		dB		27	
Gain Flatness		dB		+/-1.2	
Gain Variation	Over Temp = - 40 to +85 °C	dB		2.5	
Input Return Loss	Over Frequency	dB			-16
Output Return Loss	Over Frequency	dB			-10
Reverse Isolation	Over Frequency	dB			-41
Output P-1dB	50 to 1000 MHz	dBm		22.7	
	1250 to 2750 MHz	dBm		23.4	
	3000 to 3300 MHz	dBm		22	
Output IP3	Pout = +4 dBm/tone, Δf = 1MHz 50 to 1000 MHz	dBm		36.5	
	1250 to 2500 MHz	dBm		35	
	2750 to 3000 MHz	dBm		34	
Bias Supply	VCC	V	5	6	
Control Voltage	VCONT Amp ON	V	5	5.5	
	VCONT Amp OFF	V		2	
Bias Current	Quiescent Current Iccq	mA		155	170
	Control current Icont	mA		9	12
Thermal Resistance θ _{jc}		°C/W	TBD		
Junction Temperature Rise Above Case T _{jc}		°C	TBD		

1. All data is based on the Evaluation Circuit Board (page 5), attached to a metal heat sink block.
2. Caution: Operation beyond Absolute Maximum Ratings can degrade performance or cause permanent damage.

Absolute Maximum Ratings²

Parameter	Absolute Maximum
RF Input Power	+ 2 dBm
Supply Voltage VCC	+ 6 V
Control Voltage VCONT	+ 5.5 V
VCC Supply Current	175 mA
Operating Temperature	-40 °C to + 85 °C
Storage Temperature	-65 °C to +150 °C
Device Junction Temperature T _j , max	150°C

Operating the MAAM-007866-0P1R00

The MAAM-007866-0P1R00 can be damaged by electrostatic discharge (ESD). Use proper ESD control techniques when handling this device. To operate the MAAM-007866-0P1R00, follow these steps:

- 1.) Connect the 50 ohm load
- 2.) Apply VCC (+5.0 Vdc)
- 3.) Apply VCONT (+5.0 Vdc)
- 4.) Set the Input Power Level (P_{in})
- 5.) Turn off in reverse order

**Broadband Driver Amplifier
50 to 3300 MHz**

MAAM-007866-0P1R00

V1

Typical Performance Curves at +25°C (VCONT = +5V, 9 mA, VCC = +5 V, 155 mA)

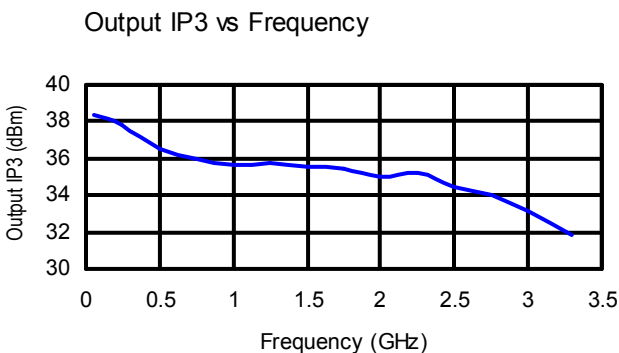
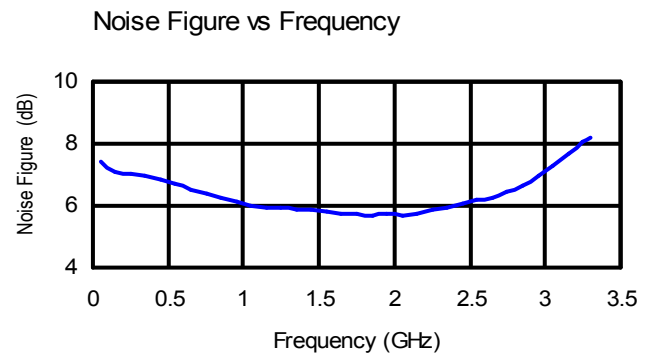
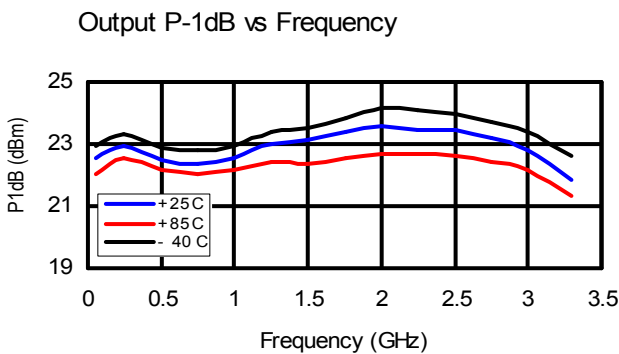
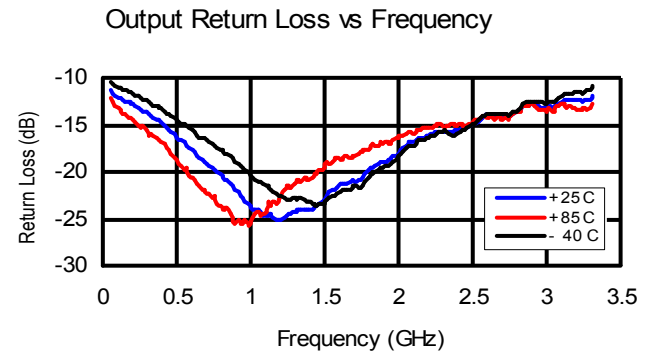
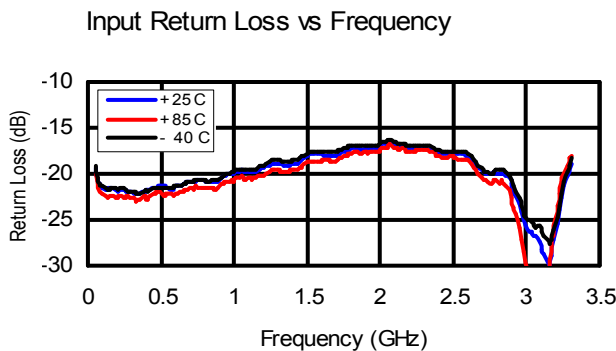
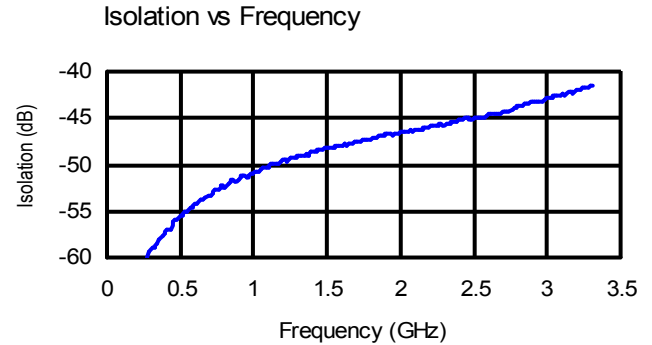
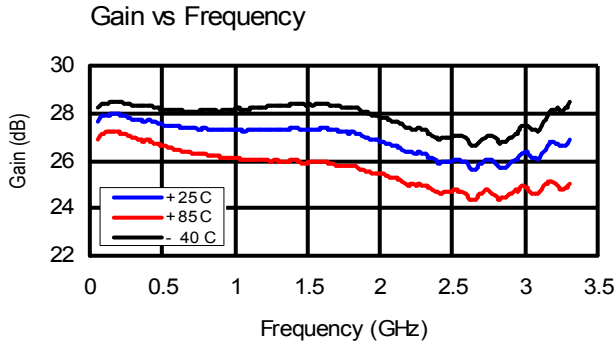

**Broadband Driver Amplifier
50 to 3300 MHz**

MAAM-007866-0P1R00

V1

Application Circuit Schematic

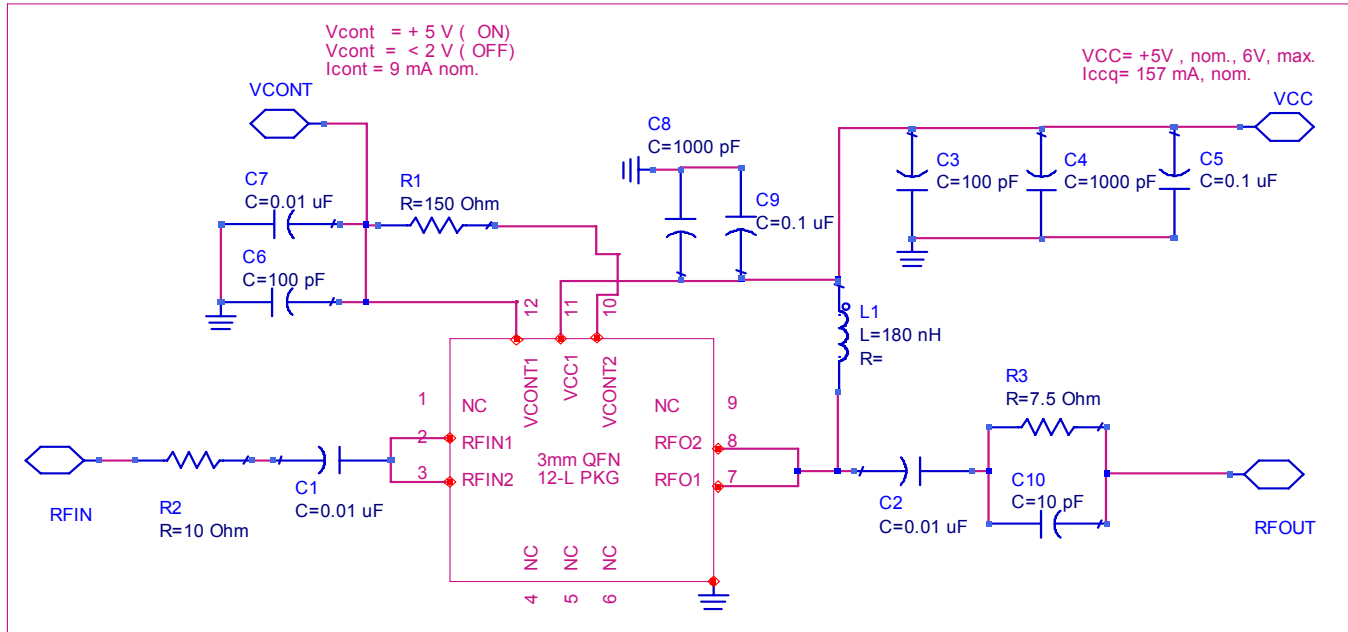

Evaluation Circuit Board Bill of Material

COMPONENT	PART NO	VALUE	SUGGESTED VENDOR
C10	NPO0402HTTP100J	10pF	KOA
C3	NPO0603HTTD101J	100pF	KOA
C6	NPO0402HTTP101J	100pF	KOA
C5	X7R0603CTTD104K	0.1uF	KOA
C4	X7R0603HTTD102K	1000pF	KOA
C8	X7R0402HTTP102K	1000pF	KOA
C9	X7R0402CTTP104K	0.1uF	KOA
C1, C2	X7R0603HTTD103K	0.01uF	KOA
C7	X7R0402CTTP103K	0.01uF	KOA
L1	0603CS-R18XJBU	180nH	COILCRAFT
R1	RK73B1JTDD151J(0603)	150 OHM	KOA
R2	RK73B1JTDD100J(0603)	10 ohm	KOA
R3	RK73B1ETTP7R5J(0402)	7.5 ohm	KOA
J1,J2	142-0701-881	RF CONN	JOHNSON
J3	TSM-105-01-S-DV	DC CONN	
U1	MAAM-007866-0P1R00	3mm PQFN 12L	TYCO
PCB	1000028554-2	GETEK, 28mil	TYCO

EVALUATION CIRCUIT BOARD LAYOUT^{1,2,3}

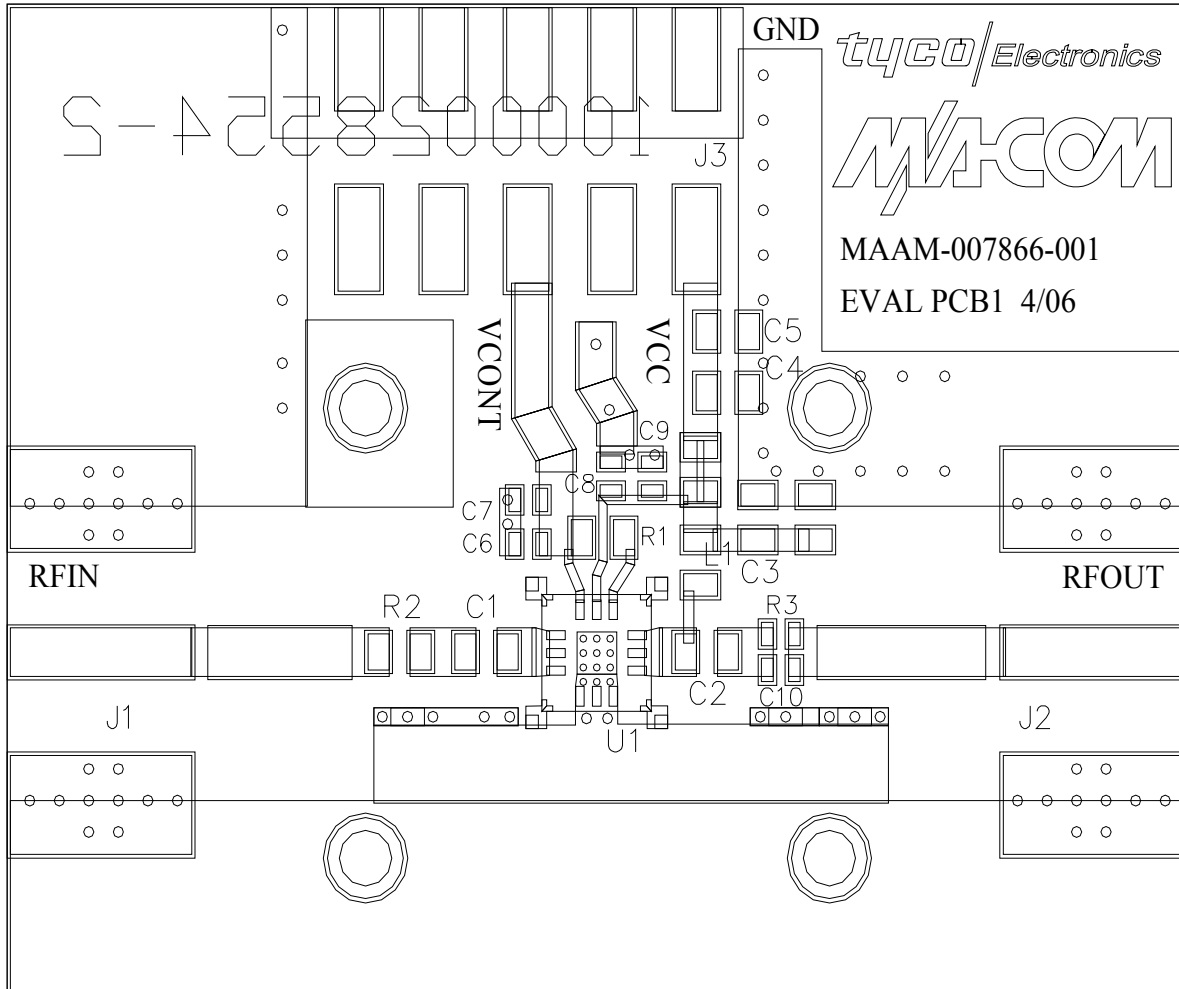

1. GETEK, 2-layer, Total Board Thickness = 32 mil.
Microstrip 50 Ohm Line width = 54 mil
Board Size: 1.4 x 1.1 inches.
2. Via Geometry shown must be used for the 3 mm QFN package backside to provide a low-inductance & low thermal resistance path to the PCB backside ground.
At least 9 vias are required. Via Diameter = 8 mils finished size with 1.0 mils minimum plating.
3. Evaluation circuit board assemblies use SnPb (tin lead) soldering process to attach all components, and are therefore not RoHS compliant.

**Broadband Driver Amplifier
50 to 3300 MHz**

MAAM-007866-0P1R00

V1

Lead-Free 3 mm 12-Lead PQFN Package Outline Dimensions

