

# Integrated Power Module Simulation Software

*Online Electrical and Thermal Simulation for IPM*

<http://www.irf.com/design-center/ipm/>

Prepared by:  
Jonah Chen

# Outline

- Introduction to IPM
- Simulation program features
- Demonstration of capabilities
  - Switching frequency analysis
  - Power loss analysis
  - Component comparison
- Conclusions

# Integrated Power Module (IPM)

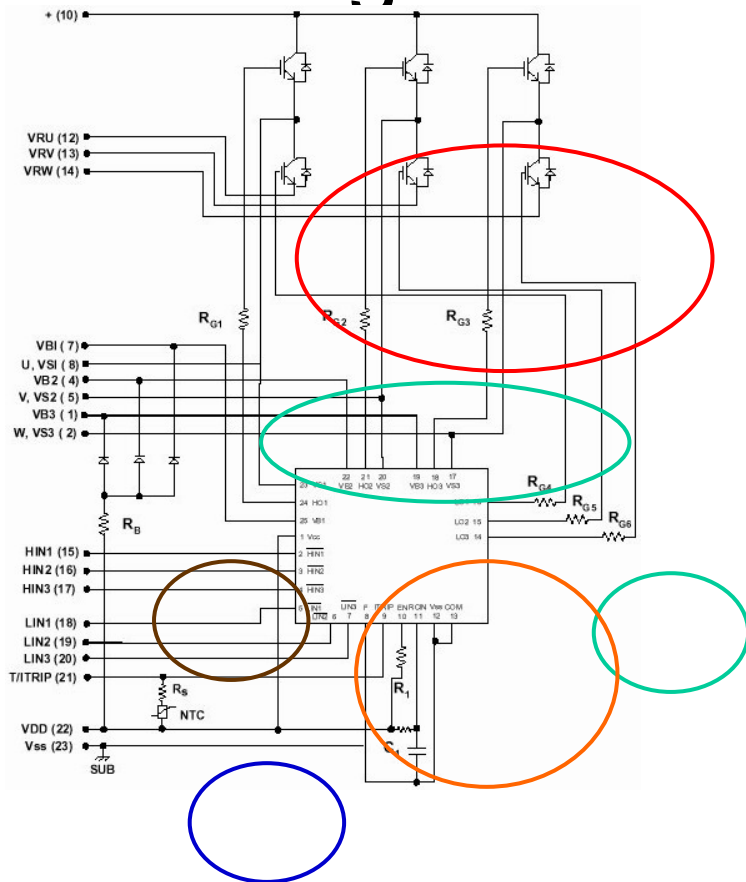

**IPM is a complete power stage solution for three-phase power inverter motor drives in one compact package for appliance applications such as washing machines and variable speed compressor drives for air-conditioning systems and commercial refrigerators.**

# How Does the IPM Work

- 1 Add bootstrap capacitors
- 2 Set RC for desired  $I_{TRIP}$
- 3 Add controller ( $\mu$ C or DSP)
- 4 Optional: Add phase shunts for current loop

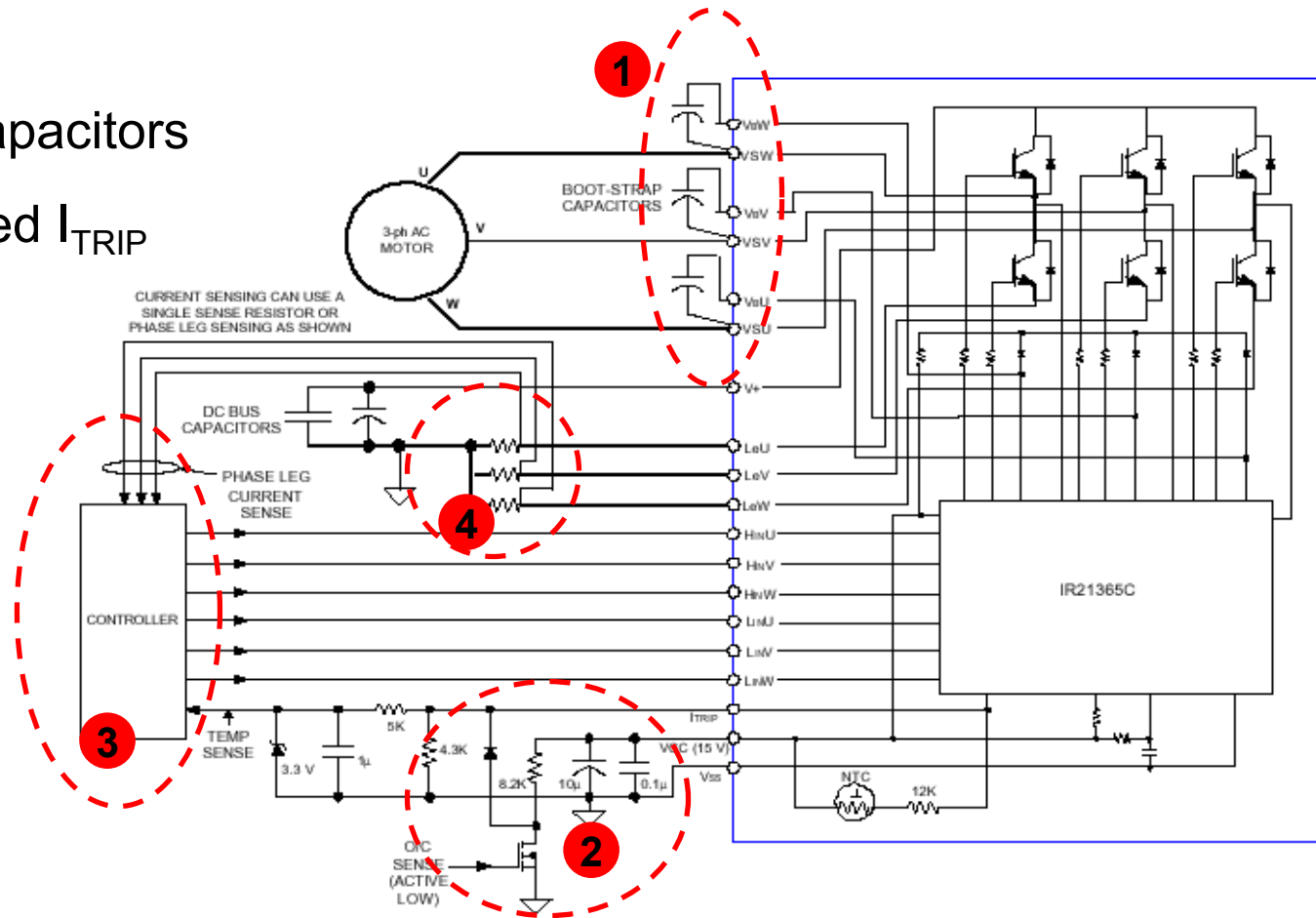

# Simulation Tool Features

- Built-in electrical and thermal models predict junction temperature under sinusoidal modulation.
- Produces curves for maximum output current vs. switching frequency.

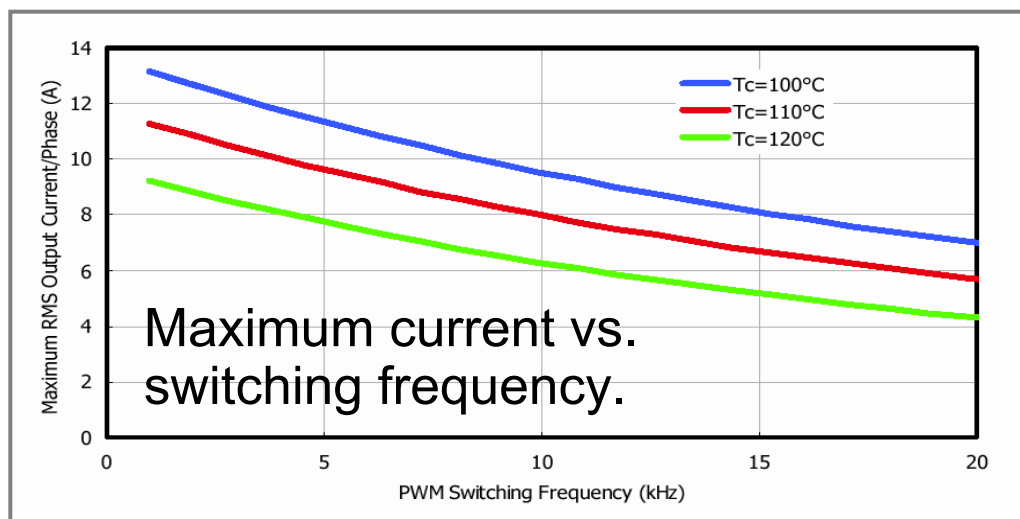

- Users can change parameters like power factor and modulation index to generate customized curves based on their specific application.

# User Interface

**Click for help!**

**1** Select up to three IPM devices for comparison.

**2** Modify parameters according to your application.

**3** Select the type of analysis.

**Component ?** IRAMS06UP60A IRAMS10UP60A IRAMX16UP60A

**Common Parameters ?**

Displacement Power Factor: 0.6 Modulation Index: 0.8

Displacement Angle [rad]: 0.93 Switching Voltage [V]: 400

Modulation Frequency [Hz]: 50 Max Junction Temperature [°C]: 150

Reset Analyze All

**Switching Frequency Analysis ?**

Case Temperature [°C]: 100 110 120

Max Switching Frequency [kHz]: 20

Step [kHz]: 2

Analyze

**Component Comparison ?**

Switching Frequency [kHz]: 20 16 12

Max Current [A]: 12.0

Step [A]: 1.2

Analyze

**Power Loss Analysis ?**

Current [A]: 8 6 4

Max Switching Frequency [kHz]: 20

Step [kHz]: 2

Analyze

# Suggested Input Range

**Common Parameters ?**

Displacement Power Factor 
 Modulation Index

Displacement Angle [rad] 
 Switching Voltage [V]

Modulation Frequency [Hz] 
 Max Junction Temperature [°C]

Input Parameter	Default Value	Suggested Min Value	Suggested Max Value
Power Factor	0.6	0.1	1
Modulation Index	0.8	0.1	1
Switching Voltage [V]	400	200	400
Modulation Freq. [Hz]	50	1	100
Switching Freq. [kHz]	20	1	24
Max Junction Temp. [°C]	150	50	175
Case Temperature [°C]	100	50	150
Current [A]	150% rated	10% rated	200% rated

# Switching Frequency Analysis

- 1 Modify parameters specific to this analysis. Three simulation cases are selected to output current comparison.

<b>Switching Frequency Analysis ?</b> <input type="button" value="Analyze"/>	Case Temperature [°C]	<input type="text" value="100"/>	<input type="text" value="110"/>	<input type="text" value="120"/>
	Max Switching Frequency [kHz]	<input type="text" value="20"/>		
	Step [kHz]	<input type="text" value="2"/>		

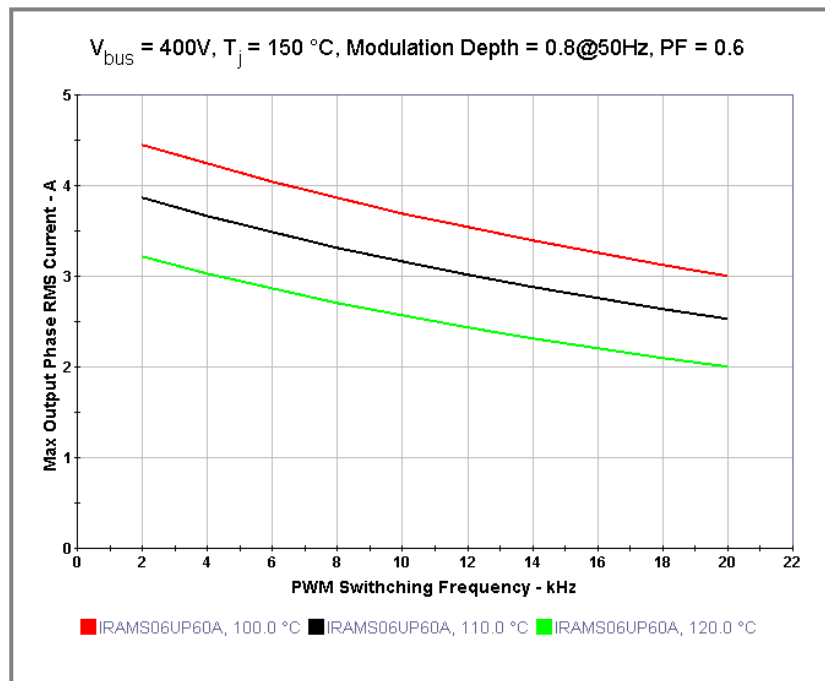

- 2 The maximum output current vs. switching frequency curves are the same as shown in IRAMS06UP60A data sheet.

# Power Loss Analysis

- 1 Input parameter specific to this analysis. Three components are selected for loss comparison.

**Power Loss Analysis ?**

Current [A]

Max Switching Frequency [kHz]

Step [kHz]

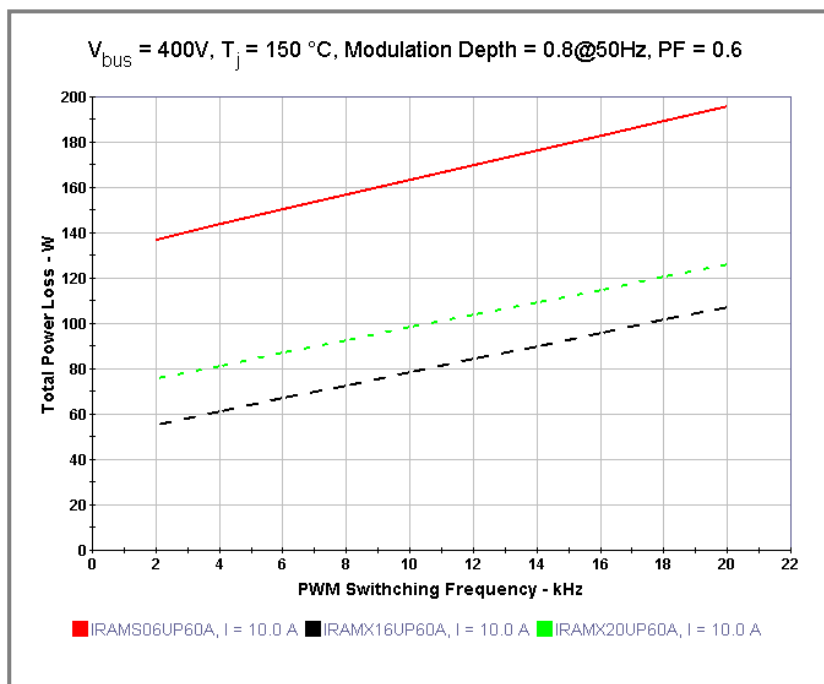

- 2 The power loss vs. switching frequency curves can be used to compare the three IPM parts: IRAM06UP60A, IRAMX16UP60A and IRAM20X60A.

# Component Comparison

- 1 Input parameter specific to this analysis.

<b>Component Comparison ?</b>	Switching Frequency [kHz]	<input type="text" value="20"/>	<input type="text"/>	<input type="text"/>
	Max Current [A]	<input type="text" value="4.5"/>		
	Step [A]	<input type="text" value="0.4"/>		
<input type="button" value="Analyze"/>				

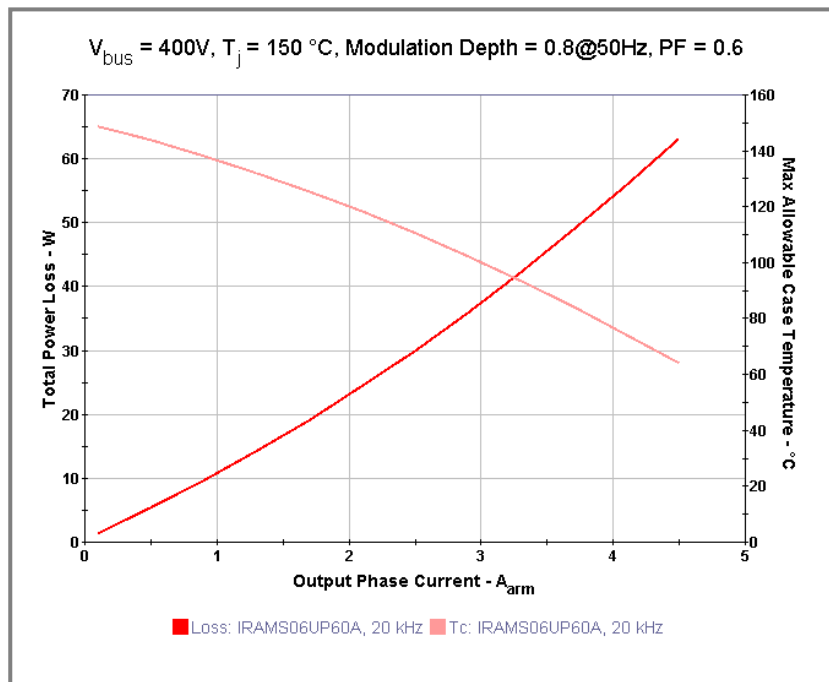

- 2 The loss and maximum case temperature curves can be used to design an appropriate heat sink for the IRAMS06UP60A.

# Contact Information

For	Contact	Email	Phone
Technical Support	Jonah Chen	<a href="mailto:Jchen3@irf.com">Jchen3@irf.com</a>	310-252-7807
Technical Support	Andrea Gorgerino	<a href="mailto:Agorger1@irf.com">Agorger1@irf.com</a>	310-726-8525

# Conclusions

- The IPM simulation software has built-in electrical and thermal models for all current IPM devices.
- Users can modify parameters like power factor and modulation index to generate customized curves based on their specific application.
- The program can help designers choose the right modules for their custom applications.